

USER INSTRUCTIONS

Digital Positioner 3200MD

*Installation
Operation
Maintenance*



Experience In Motion

Contents

1	Terms Concerning Safety	3	8	Maintenance and Repair	21
2	General Information	3	8.1	Driver Module Assembly	21
3	Unpacking and Storage	3	8.2	Regulator	23
3.1	Unpacking	3	8.3	Checking or Setting Internal Regulator Pressure	24
3.2	Storage	3	8.4	Spool Valve	25
3.3	Pre-installation Inspection	3	8.5	Spool Valve Cover	25
4	Logix 3200MD Positioner Overview	4	8.6	Stem Position Sensor	26
4.1	Specifications	4	8.7	Main PCB Assembly	27
4.2	Positioner Operation	6	8.8	Pressure Sensor Board	27
4.3	Detailed Sequence of Positioner Operations	7	8.9	Customer Interface Board	28
5	Mounting and Installation	8	9	Optional Hardware	29
5.1	Mounting to Valtek Linear Mark One Valves	8	9.1	Vented Design	29
5.2	Mounting to Standard Valtek Rotary Valves	9	9.2	HART Modem	30
5.3	Optional Valtek Rotary Mounting Procedure	11	9.3	4-20 mA Analog Output Board	30
5.4	Tubing Positioner to Actuator	11	10	Parts List	32
6	Wiring and Grounding Guidelines	12	11	Logix 3200MD Spare Parts Kits	34
6.1	4-20 mA Command Input Wiring	13	12	Logix 3200MD Mounting Kits	35
6.2	Grounding Screw	13	12.1	Valtek Mounting Kits	35
6.3	Compliance Voltage	13	12.2	Logix O.E.M. Mounting Kits	36
6.4	Cable Requirements	13	12.3	NAMUR Accessory Mounting Kit Part Numbers	36
6.5	Intrinsically Safe Barriers	14	13	Frequently Asked Questions	37
7	Startup	14	14	How to Order	38
7.1	Logix 3200MD Local Interface	14	15	Troubleshooting	39
7.2	Initial DIP Switch Settings Operation	14			
7.3	Operation of Configuration DIP Switch Settings	15			
7.4	Setup of the Cal Dip-Switch for the Quick Calibration operating mode.	16			
7.5	QUICK-CAL Operation	16			
7.6	Local control of valve position	17			
7.7	Factory Reset	17			
7.8	Command Reset	17			
7.9	Version number checking	17			
7.10	Logix 3200MD Status Condition	17			
7.11	ValveSight Configuration and Diagnostic Software and HART 375 Handheld Communicator	18			

1 Terms Concerning Safety

The safety terms DANGER, WARNING, CAUTION and NOTE are used in these instructions to highlight particular dangers and/or to provide additional information on aspects that may not be readily apparent.

β DANGER: Indicates that death, severe personal injury and/or substantial property damage will occur if proper precautions are not taken.

χ WARNING: Indicates that death, severe personal injury and/or substantial property damage can occur if proper precautions are not taken.

α CAUTION: Indicates that minor personal injury and/or property damage can occur if proper precautions are not taken.

NOTE: indicates and provides additional technical information, which may not be very obvious even to qualified personnel. Compliance with other, not particularly emphasized notes, with regard to transport, assembly, operation and maintenance and with regard to technical documentation (e.g., in the operating instruction, product documentation or on the product itself) is essential, in order to avoid faults, which in themselves might directly or indirectly cause severe personal injury or property damage.

2 General Information

The following instructions are designed to assist in unpacking, installing and performing maintenance as required on Valtek® Logix® 3200MD digital positioners. Series 3000 is the term used for all the positioners herein; however, specific numbers indicate features specific to model (i.e., Logix 3200 indicates that the positioner has HART® protocol). See Logix 3200MD Model Number table in this manual for a breakdown of specific model numbers. Product users and maintenance personnel should thoroughly review this bulletin prior to installing, operating, or performing any maintenance on the valve.

Separate Valtek Flow Control Products Installation, Operation, Maintenance instructions cover the valve (such as IOM 1 or IOM 27) and actuator (such as IOM 2 or IOM 31) portions of the system and other accessories. Refer to the appropriate instructions when this information is needed.

To avoid possible injury to personnel or damage to valve parts, WARNING and CAUTION notes must be strictly followed. Modifying this product, substituting non-factory parts or using maintenance procedures other than outlined could drastically affect performance and be hazardous to personnel and equipment, and may void existing warranties.

WARNING: Standard industry safety practices must be adhered to when working on this or any process control product. Specifically, personal protective and lifting devices must be used as warranted.

3 Unpacking and Storage

3.1 Unpacking

1. While unpacking the Logix 3200MD positioner, check the packing list against the materials received. Lists describing the system and accessories are included in each shipping container.
2. When lifting the system from the shipping container, position lifting straps to avoid damage to mounted accessories. Systems with valves up to six inches may be lifted by actuator lifting ring. On larger systems, lift unit using lifting straps or hooks through the yoke legs and outer end of body.

χ WARNING: When lifting a valve/actuator assembly with lifting straps, be aware the center of gravity may be above the lifting point. Therefore, support must be given to prevent the valve/actuator from rotating. Failure to do so can cause serious injury to personnel or damage to nearby equipment.

3. In the event of shipping damage, contact the shipper immediately.
4. Should any problems arise, contact a Flowserve Flow Control Division representative.

3.2 Storage

Control valve packages (a control valve and its instrumentation) can be safely stored in an enclosed building that affords environmental protection; heating is not required. Control valve packages must be stored on suitable skids, not directly on the floor. The storage location must also be free from flooding, dust, dirt, etc.

3.3 Pre-installation Inspection

If a valve control package has been stored for more than one year, inspect one actuator by disassembling it per the appropriate Installation, Operation, and Maintenance Instructions (IOM) prior to valve installation. If O-rings are out-of-round, deteriorated, or both, they must be replaced and the actuator rebuilt. All actuators must then be disassembled and inspected. If the actuator O-rings are replaced, complete the following steps:

1. Replace the pressure-balance plug O-rings.
2. Inspect the solenoid and positioner soft goods and replace as necessary.

4 Logix 3200MD Positioner Overview

The Logix 3200MD digital positioner is a two-wire 4-20 mA input digital valve positioner. The positioner is configurable through the local user interface. The Logix 3200MD utilizes the HART protocol to allow two-way remote communications with the positioner. The Logix 3200MD positioner can control both double- and single-acting actuators with linear or rotary mountings. The positioner is completely powered by the 4-20 mA input signal. Start up current must be at least 3.6 mA without AO card or 3.85 mA with AO card.

4.1 Specifications

Table I: Electrical Specifications

Power Supply	Two-wire, 4-20 mA 10.0 to 30.0 VDC
Compliance Voltage	10.0 VDC @ 20 mA
Effective Resistance	495 Ω @ 20 mA Typical Add 20 Ω when HART communication active
Communications	HART Protocol
Minimum Operating Current	3.6 mA without AO board 3.85 mA with AO board
Maximum Voltage	30.0 VDC

Table II: ValveSight Suite Software Specifications

Computer	Minimum Pentium processor running Windows 95, 98, NT, 2000, XP, 32 MB total memory (64 MB recommended), 30 MB available hard disk space, CD-ROM drive
Ports	1 minimum available with 8 maximum possible. (Can also communicate via PCMCIA and USB connections)
HART Modem	RS-232/PCMCIA card/USB
HART Filter	May be required in conjunction with some DCS hardware
HART MUX	MTL 4840/ELCON 2700

Table III: Environmental Conditions

Operating Temperature Range	Standard	-4° to 176°F (-20° to 80°C)
	Low	-40° to 176°F (-40° to 80°C)
Transport and Storage Temperature Range	-40° to 176°F (-40° to 80°C)	
Operating Humidity	0 - 100% non-condensing	

Note: The air supply must conform to ISA Standard ISA 7.0.01 (a dew point at least 18 degrees Fahrenheit below ambient temperature, particle size below five microns—one micron recommended—and oil content not to exceed one part per million).

Table IV: Physical Specifications

Housing Material	Cast, powder-painted aluminum, stainless steel
Soft Goods	Buna-N / Florosilicone
Weight	8.3 pounds (3.9 kg) aluminum 20.5 pounds (9.3 kg) stainless steel

Table V: Positioner Specifications

Deadband	<0.1% full scale
Repeatability	<0.05% full scale
Linearity	<0.5% (rotary), <0.8%, (sliding stem) full scale
Air Consumption	<0.3 SCFM (0.5 Nm ³ /hr) @ 60 psi (4 barg)
Air Capacity	12 SCFM @ 60 psi (4 barg) (0.27 Cv)

Table VI: 4 to 20 mA Analog Output Specifications

Potential Range of Rotation	40° - 95°
Power Supply Range	12.5 to 40 VDC, (24 VDC typical)
Maximum Load Resistance (ohms)	(Supply voltage - 12.5) / 0.02
Current Signal Output	4-20 mA
Linearity	1.0% F.S.
Repeatability	0.25% F.S.
Hysteresis	1.0% F.S.
Operating Temperature	-40° to 176°F, -40° to 80°C

Table VII: Hazardous Area Certifications

Notified Body	Certification Option	Approval	Entity Parameters	Temperature Code	Enclosure Rating
	-10	Explosionproof: Class I, Div 1, Groups B,C,D Dust Ignition Proof: Class II, III, Div 1, Groups EFG (See Warning No. 1, 2)	Not Applicable	T6 T _{amb} ≤ = 60°C	NEMA 4X
	-10	Intrinsically Safe: Class I, II, III, Div 1, Groups A,B,C,D Class 1, Zone 0, AEx ia IIC (See Warning No. 2,3)	V _{max} = 30 Volts I _{max} = 100mA P _{max} = 800mW C _i = 30 nF L _i = 0 (refer to control drawing No. 198736)	T4 T _{amb} ≤ = 85°C T5 T _{amb} ≤ = 55°C	NEMA 4X
	-10	Non-Incendive: Class I, Div 2, Groups A,B,C,D (See Warning No. 2)	Install per NEC Article 501-4 when barriers are not used.	T4 T _{amb} ≤ = 85°C T5 T _{amb} ≤ = 55°C	NEMA 4X
	-10	Explosionproof: Class I, Div 1, Groups B,C,D Class II, Div 1, Groups E,F,G Class III (See Warning No. 1, 2)	Not Applicable	-25° ≤ Ta ≤ +40°C	Type 4X
	10	Intrinsically Safe: Class I, II, III, Div 1, Groups A,B,C,D (See Warning No. 2, 3)	V _{max} = 30 Volts I _{max} = 100mA P _{max} = 800mW C _i = 30 nF L _i = 0 (refer to control drawing No. 198736)	T4 T _{amb} ≤ = 80°C	Type 4X
	10	Non-Incendive: Class I, II, Div 2, Groups A,B,C,D (See Warning No. 2)	Not Required	T4 T _{amb} ≤ = 80°C	Type 4X
	-07	Explosionproof (Flameproof): II 2 GD Ex d IIB + H ₂ Ex tD A21 T95°C (See Warning No. 1, 2)	Not Required	T5 (T = -40°C to + 80°C)	IP65
	-04 or -15	Intrinsically Safe: II 1 G Ex ia IIC (See Warning No. 2, 3)	U _i = 30 Volts I _i = 100mA P _i = 800mW C _i = 30 nF L _i = 0 C _o = 36 nF	T4 (T _{amb} -40°C to + 85°C) T5 (T _{amb} -40°C to + 55°C)	IP65
	-03 or -04 or -20	Non-Incendive: II 3 G Ex nL nA IIC (See Warning No. 2)	Not Required	T4 T _{amb} -40°C to + 85°C T5 T _{amb} -40°C to + 55°C)	IP65
IECEX	-16	Explosionproof (Flameproof): Ex d IIB + H ₂ (See Warning No. 1, 2)	Not Required	T5 (T _{amb} -20°C to + 55°C) T5 (T _{amb} -40°C to + 80°C)	IP65
	-21	Intrinsically Safe: Ex ia IIC (See Warning No. 2, 3)	U _i = 30 Vdc I _i = 100mA P _i = 0.8W C _i = 30 nF L _i = 0	T4 (T _{amb} -40°C to + 85°C)	IP65
	-06	Explosionproof (Flameproof): BR-Ex d IIB + H ₂ (See Warning No. 1, 2)	Not Required	T5 (-40°C ≤ Ta ≤ + 80°C)	IP65
	-06 or -22	Intrinsically Safe: BR- Ex ia IIC (See Warning No. 2, 3)	U _i = 30 Vdc I _i = 100mA P _i = 800mW C _i = 30 nF L _i = 0 C _o = 36 nF	T5 (-40°C ≤ Ta ≤ + 55°C) T4 (-40°C ≤ Ta ≤ + 85°C)	IP65
KOSHA	-07	Explosionproof (Flameproof) Ex d IIB + H ₂ (See Warning No. 1, 2)	Not Required	T5 (T = -40°C to + 80°C)	IP65

⚠ WARNINGS:

- In order to maintain the explosionproof certifications do not remove or loosen covers during operation.
- To avoid the possibility of static discharge clean only with a damp cloth.
- The positioner must be connected to suitable rated intrinsically safe equipment, and must be installed in accordance with intrinsically safe installation standards.

4.2 Positioner Operation

The Logix 3200MD positioner is an electric feedback instrument. Figure 1 shows a Logix 3200MD positioner installed on a double-acting linear actuator for air-to-open action.

The Logix 3200MD receives power from the two-wire, 4-20 mA input signal. However, since this positioner utilizes HART communications, two sources can be used for the command signal: Analog and Digital. In Analog source, the 4-20 mA signal is used for the command source. In Digital source, the level of the input 4-20 mA signal is ignored and a digital signal, sent via HART, is used as the command source. The command source can be accessed with ValveSight software, the HART 375 communicator, or other host software.

Whether in Analog or Digital Source, 0% is always defined as the valve closed position and 100% is always defined as the valve open position. In Analog Source, the 4-20 mA signal is converted to a percentage. During loop calibration, the signals corresponding to 0% and 100% are defined.

The input signal in percent passes through a characterization/limits modifier block. The positioner no longer uses CAMs or other

mechanical means to characterize the output of the positioner. This function is done in software, which allows for in-the-field customer adjustment. The positioner has three basic modes: *Linear*, *Equal Percent (=%)* and *Custom* characterization. In *Linear* mode, the input signal is passed straight through to the control algorithm in a 1:1 transfer. In *Equal Percent (=%)* mode, the input signal is mapped to a standard 30:1 rangeability =% curve. If *Custom* characterization is enabled, the input signal is mapped to either a default =% output curve or a custom, user-defined 21-point output curve. The custom user-defined 21-point output curve is defined using a handheld or ValveSight software. In addition, two user-defined features, *Soft Limits* and *MPC* (Minimum Position Cutoff), may affect the final input signal. The actual command being used to position the stem, after any characterization or user limits have been evaluated, is called the *Control Command*.

The Logix 3200MD uses a two-stage, stem-positioning algorithm. The two stages consist of an inner-loop, spool control and an outer-loop, stem position control. Referring again to Figure 1, a stem position sensor provides a measurement of the stem movement. The *Control Command* is compared against the *Stem Position*. If any deviation exists, the control algorithm sends a signal to the inner-loop control to move the spool up or down, depending upon

Figure 1: Logix 3200MD Digital Positioner Schematic (air-to-open configuration)

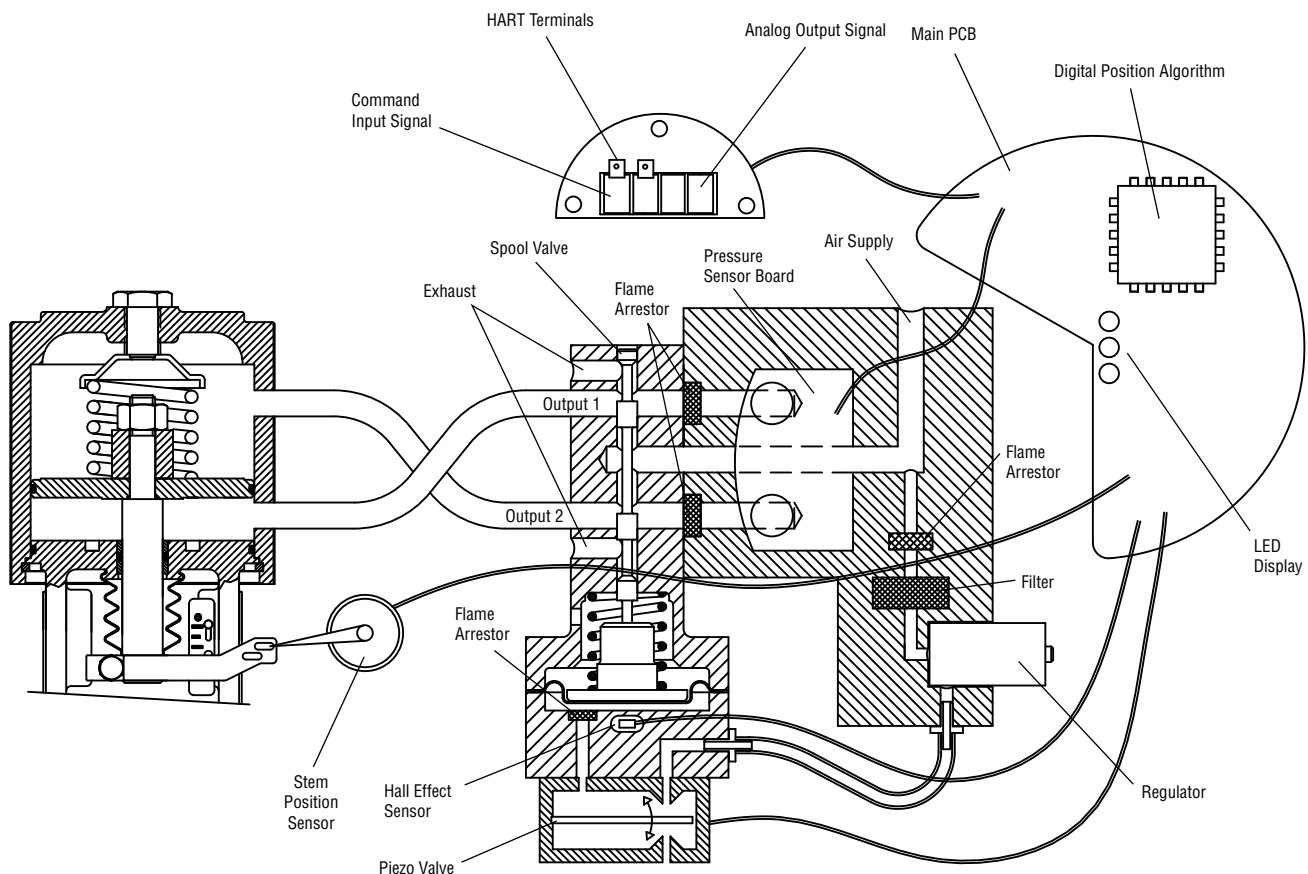
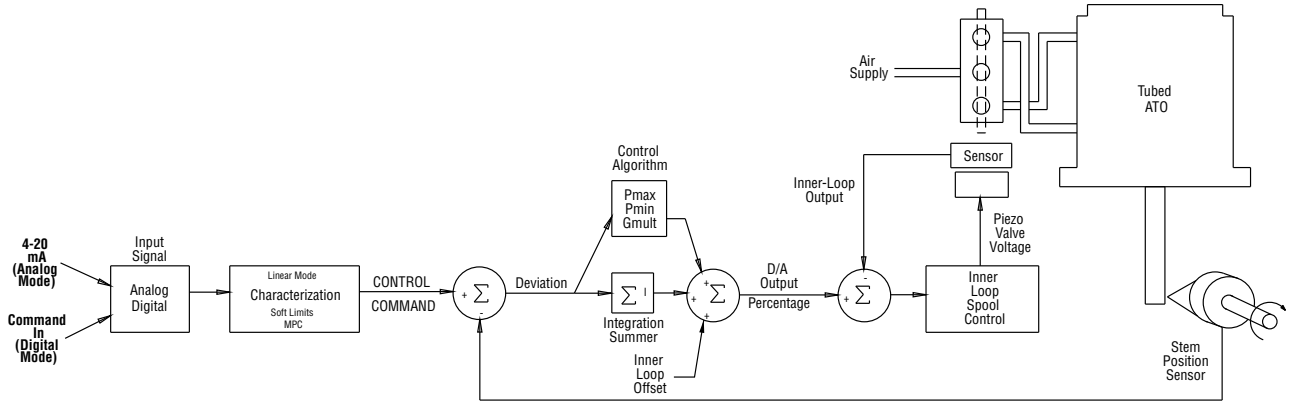

Figure 2: System Positioning Algorithm



the deviation. The inner-loop then quickly adjusts the spool position. The actuator pressures change and the stem begins to move. The stem movement reduces the deviation between *Control Command* and *Stem Position*. This process continues until the deviation goes to zero.

The inner-loop controls the position of the spool valve by means of a driver module. The driver module consists of a temperature-compensated hall effect sensor and a piezo valve pressure modulator. The piezo valve pressure modulator controls the air pressure under a diaphragm by means of a piezo beam bender. The piezo beam deflects in response to an applied voltage from the inner-loop electronics. As the voltage to the piezo valve increases, the piezo beam bends, closing off against a nozzle causing the pressure under the diaphragm to increase. As the pressure under the diaphragm increases or decreases, the spool valve moves up or down respectively. The hall effect sensor transmits the position of the spool back to the inner-loop electronics for control purposes.

4.3 Detailed Sequence of Positioner Operations

A more detailed example explains the control function. Assume the unit is configured as follows:

- Unit is in *Analog command source*.
- *Custom* characterization is disabled (therefore characterization is *Linear*).
- No soft limits enabled. No MPC set.
- Valve has zero deviation with a present input signal of 12 mA.
- Loop calibration: 4 mA = 0% command, 20 mA = 100% command.
- Actuator is tubed and positioner is configured air-to-open.

Given these conditions, 12 mA represents a *Command source* of 50 percent. *Custom characterization* is disabled so the *Command source* is passed 1:1 to the *Control Command*. Since zero deviation exists, the *Stem Position* is also at 50 percent. With the stem at the desired position, the spool valve will be at a middle position that balances the pressures above and below the piston in the actuator. This is commonly called the *null* or *balanced* spool position.

Assume the input signal changes from 12 mA to 16 mA. The positioner sees this as a *Command source* of 75 percent. With *Linear characterization*, the *Control Command* becomes 75 percent. Deviation is the difference between *Control Command* and *Stem Position*: Deviation = 75% - 50% = +25%, where 50 percent is the present stem position. With this positive deviation, the control algorithm sends a signal to move the spool up from its present position. As the spool moves up, the supply air is applied to the bottom of the actuator and air is exhausted from the top of the actuator. This new pressure differential causes the stem to start moving towards the desired position of 75 percent. As the stem moves, the *Deviation* begins to decrease. The control algorithm begins to reduce the spool opening. This process continues until the *Deviation* goes to zero. At this point, the spool will be back in its null or balanced position. Stem movement will stop and the desired stem position is now achieved.

One important parameter has not been discussed to this point: Inner loop offset. Referring to Figure 2, a number called *Inner loop offset* is added to the output of the control algorithm. In order for the spool to remain in its null or balanced position, the control algorithm must output a non-zero spool command. This is the purpose of the *Inner loop offset*. The value of this number is equivalent to the signal that must be sent to the spool position control to bring it to a null position with zero deviation. This parameter is important for proper control and is optimized and set automatically during stroke calibration.

Figure 3: Linear Mark One Control Valve Mounting

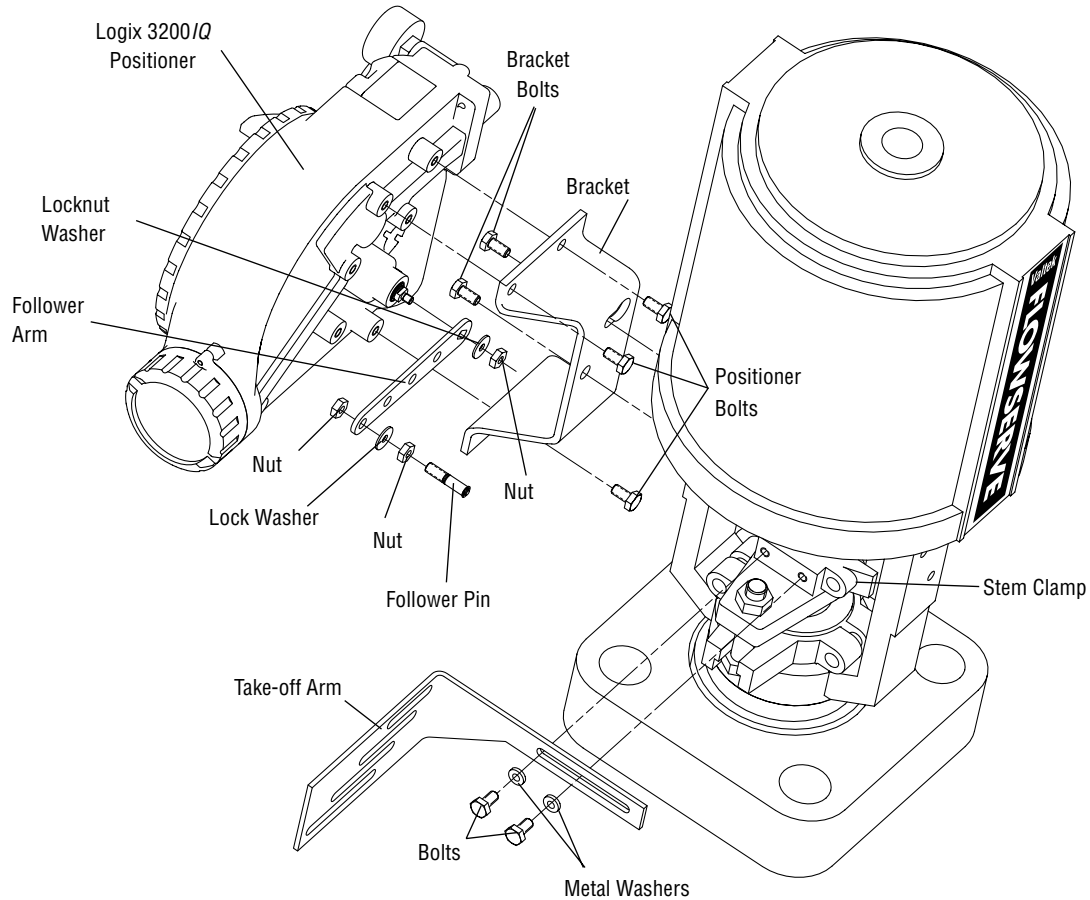

5 Mounting and Installation

5.1 Mounting to Valtek Linear Mark One Valves

To mount a Logix 3200MD positioner to a Valtek linear Mark One valve, refer to Figure 3 and proceed as outlined below. The following tools are required:

- $\frac{9}{16}$ " open-end wrench (or $\frac{1}{2}$ " for spud sizes 2.88 and smaller)
- $\frac{7}{16}$ " box wrench
- $\frac{3}{8}$ " open-end wrench

1. Remove washer and nut from follower pin assembly. Insert pin into the appropriate hole in follower arm, based on stroke length. The stroke lengths are stamped next to their corresponding holes in the follower arms. Make sure the unthreaded end of the pin is on the stamped side of the arm. Reinstall lock washer and tighten nut to complete follower arm assembly.

2. Slide the double-D slot in the follower arm assembly over the flats on the position feedback shaft in the back of the positioner. Make sure the arm is pointing toward the customer interface side of the positioner. Slide lock washer over the threads on the shaft and tighten down the nut.
3. Align the bracket with the three outer mounting holes on the positioner. Fasten with $\frac{1}{4}$ " bolts.
4. Screw one mounting bolt into the hole on the yoke mounting pad nearest the cylinder. Stop when the bolt is approximately $\frac{3}{16}$ " from being flush with mounting pad.
5. Slip the large end of the teardrop shaped mounting hole in the back of the positioner/bracket assembly over the mounting bolt. Slide the small end of the teardrop under the mounting bolt and align the lower mounting hole.
6. Insert the lower mounting bolt and tighten the bolting.

7. Position the take-off arm mounting slot against the stem clamp mounting pad. Apply Loctite 222 to the take-off arm bolting and insert through washers into stem clamp. Leave bolts loose.
8. Slide the appropriate pin slot of the take-off arm, based on stroke length, over the follower arm pin. The appropriate stroke lengths are stamped by each pin slot.
9. Center the take-off arm on the rolling sleeve of the follower pin.
10. Align the take-off arm with the top plane of the stem clamp and tighten bolting. Torque to 120 in-lb.

NOTE: If mounted properly, the follower arm should be horizontal when the valve is at 50% stroke and should move approximately $\pm 30^\circ$ from horizontal over the full stroke of the valve. If mounted incorrectly, a stroke calibration error will occur and the indicator lights will blink a RGGY code indicating the position sensor has gone out of range on one end of travel. Reposition the feedback linkage or rotate the position sensor to correct the error.

5.2 Mounting to Standard Valtek Rotary Valves (See Figure 4)

The standard rotary mounting applies to Valtek valve/actuator assemblies that do not have mounted volume tanks or handwheels. The standard mounting uses a linkage directly coupled to the valve shaft. This linkage has been designed to allow for minimal misalignment between the positioner and the actuator. The tools required for the following procedure are:

- $\frac{5}{32}$ " Allen wrench
- $\frac{1}{2}$ " open-end wrench
- $\frac{7}{16}$ " open-end wrench
- $\frac{3}{8}$ " socket with extension
- $\frac{3}{16}$ " nutdriver

1. Fasten the spline lever adapter to the splined lever using two 6 x $\frac{1}{2}$ " self-tapping screws.

Figure 4: Standard Rotary Mounting

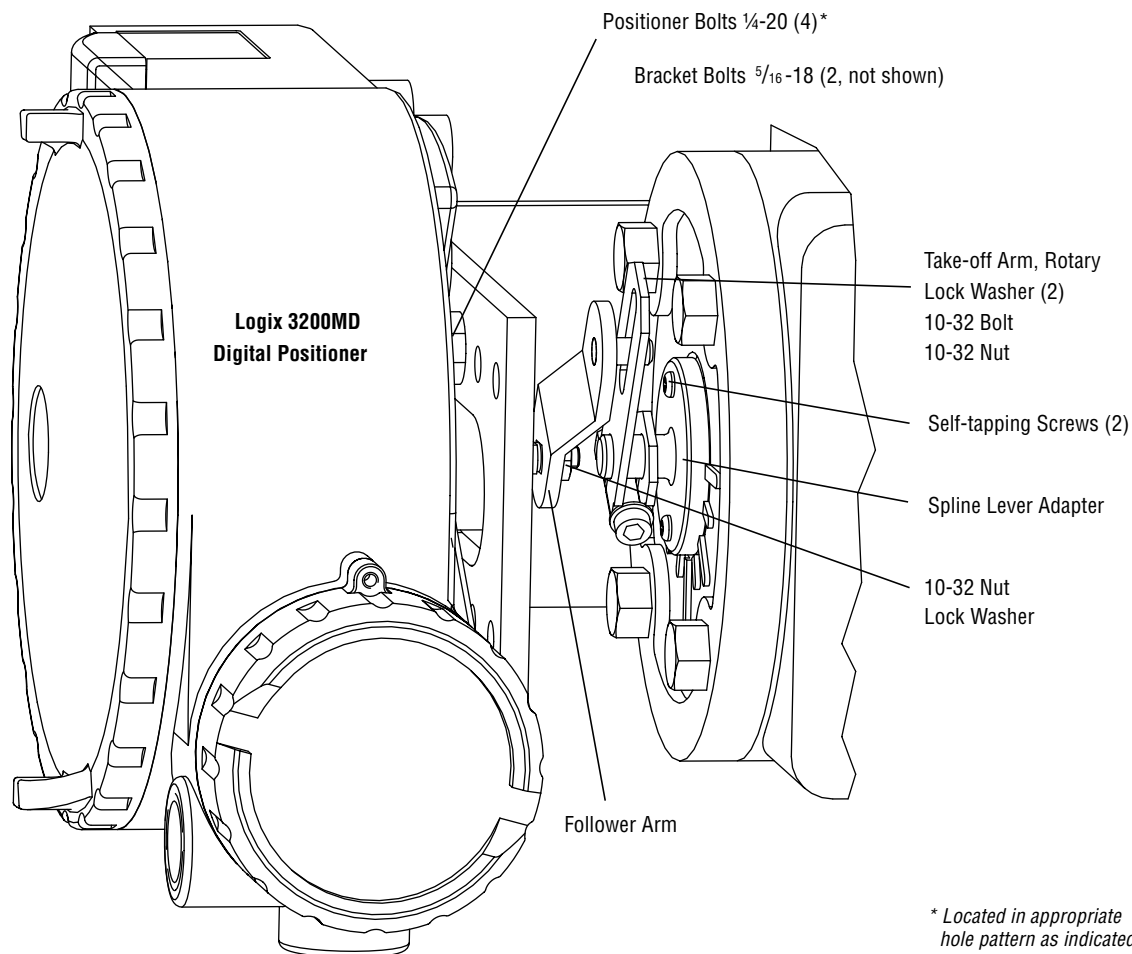

* Located in appropriate hole pattern as indicated on bracket. (25, 50, 100/200)

2. Slide the take-off arm assembly onto the spline lever adapter shaft. Insert the screw with star washer through the take-off arm and add the second star washer and nut. Tighten nut with socket so arm is lightly snug on the shaft but still able to rotate. This will be tightened after linkage is correctly oriented.
3. Attach follower arm to positioner feedback shaft using the star washer and 10-32 nut.

NOTE: The arm will point up when feedback shaft is in the free position.
4. Using four 1/4-20 x 1/2" bolts, fasten positioner to universal bracket using appropriate hole pattern (stamped on bracket).
5. Using a 1/2" end wrench and two 5/16-18 x 1/2" bolts, attach bracket to actuator transfer case pad. Leave these bolts slightly loose until final adjustments are made.

6. Rotate take-off arm so the follower pin will slide into the slot on the take-off arm. Adjust the bracket position as needed noting the engagement of the follower pin and the take-off arm slot. The pin should extend approximately 1/16" past the take-off arm. When properly adjusted, securely tighten the bracketing bolts.

Orienting the Take-off Arm for Final Lock Down

1. Tube the Logix 3200MD positioner to the actuator according to the instructions given in Section 5.4, "Tubing Positioner to Actuator."
2. **With supply pressure off**, rotate the follower arm in the same direction the shaft would rotate upon a loss of supply pressure. When the mechanical stop of the follower arm (positioner) is reached, rotate back approximately 15 degrees.
3. Hold the take-off arm in place; tighten the screw of the take-off arm.

Figure 5: Optional Rotary Mounting

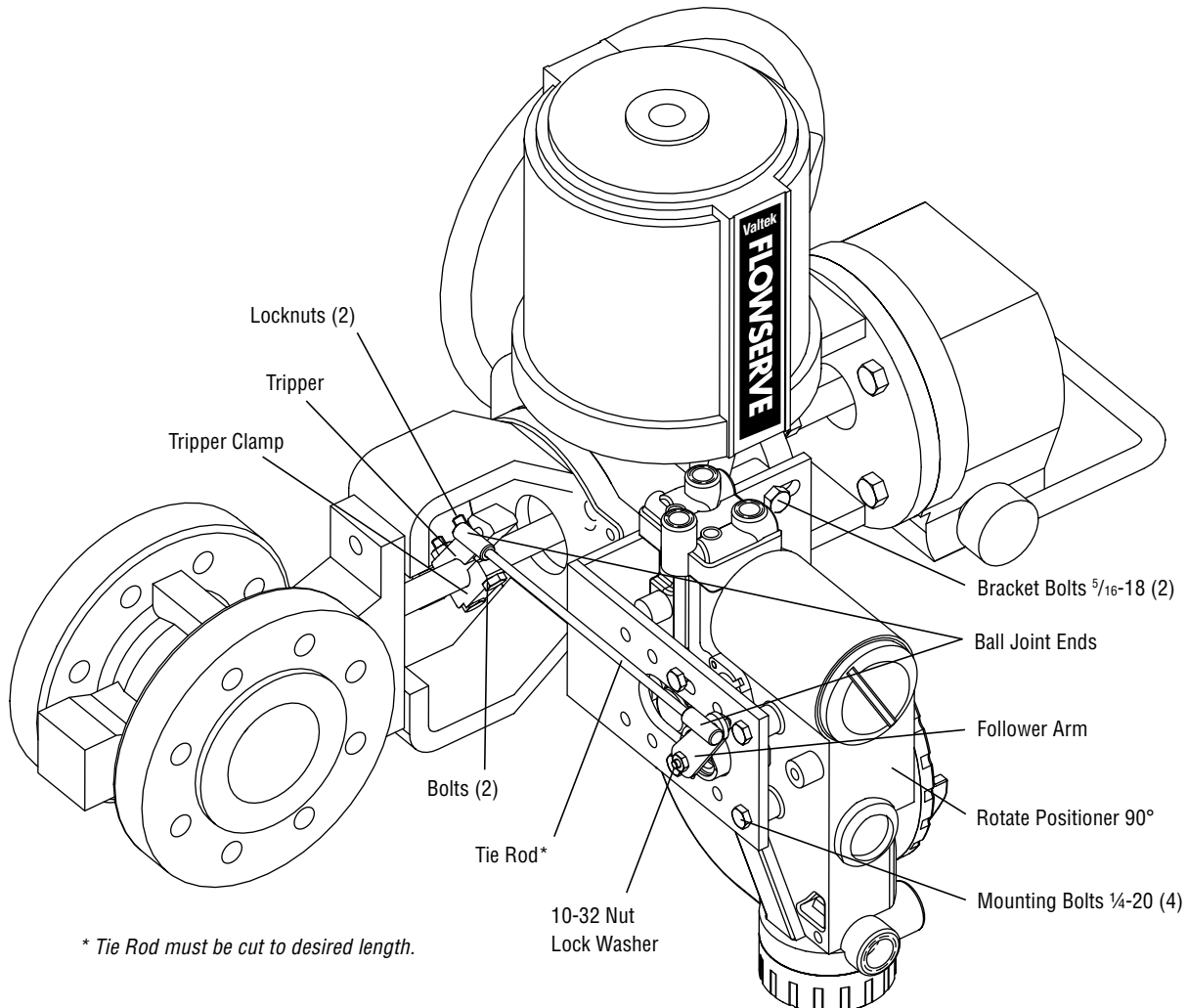

NOTE: The take-off arm should be snug enough to hold the follower arm in place but allow movement when pushed.

4. Connect regulated air supply to appropriate port in manifold.
5. Remove main cover and locate DIP switches and QUICK-CAL button.
6. Refer to sticker on main board cover and set DIP switches accordingly. (A more detailed explanation of the DIP switch settings is given in Section 7, "Startup.")
7. Press the QUICK-CAL button for three to four seconds or until the positioner begins to move. The positioner will now perform a stroke calibration.
8. If the calibration was successful the green LED will blink GGGG or GGGY and the valve will be in control mode. Continue with step 9. If calibration failed, as indicated by a RGGY blink code, the A/D feedback values were exceeded and the arm must be adjusted away from the positioners limits. Return to step 2 and rotate the arm back approximately 10 degrees.

NOTE: Remember to remove the air supply before re-adjusting take-off arm.

9. Tighten the nut on the take-off arm. The socket head screw of the take-off arm must be tight, about 40 in-lb.

NOTE: If the take-off arm slips, the positioner must be recalibrated.

⚠ **WARNING:** Failure to follow this procedure will result in positioner and/or linkage damage. Check air-action and stroke carefully before lockdown of take-off arm to spline lever adapter.

5.3 Optional Valtek Rotary Mounting Procedure (See Figure 5)

The optional rotary mounting applies to Valtek valve/actuator assemblies that are equipped with mounted volume tanks or handwheels. The optional mounting uses a four-bar linkage coupled to the valve shaft. The following tools are required:

- 3/8" open-end wrench
- 7/16" open-end wrench
- 1/2" open-end wrench

1. Using a 1/2" open-end wrench and two 5/16-18 x 1/2" bolts, attach bracket to actuator transfer case pads. Leave bracket loose to allow for adjustment.
2. Using four 1/4-20 x 1/2" bolts and a 7/16" open-end wrench, fasten positioner to universal bracket, using the four-hole pattern that locates the positioner the farthest from the valve. Rotate positioner 90 degrees from normal so gauges are facing upward.
3. Attach follower arm to positioner feedback shaft, using the star washer and 10-32 nut.
4. Attach tripper and tripper clamp to valve shaft using two 1/4-20 bolts and two 1/4-20 locknuts. Leave tripper loose on shaft until final adjustment.
5. Thread ball joint linkage end to tripper and tighten (thread locking compound such as Loctite is recommended to prevent back threading). Adjust the length of tie rod so follower arm and tripper rotate parallel to each other (the rod must be cut to the desired length). Connect the other ball joint end to follower arm using a star washer and a 10-32 nut.
6. Tighten bracket and tripper bolting.
7. Check for proper operation, note direction of rotation.

⚠ **WARNING:** If rotating in wrong direction, serious damage will occur to the positioner and/or linkage. Check air action and stroke direction carefully before initiating operation.

5.4 Tubing Positioner to Actuator

The Logix 3200MD digital positioner is insensitive to supply pressure changes and can handle supply pressures from 30 to 150 psig. A supply regulator is recommended if the customer will be using the diagnostic features of the Logix 3200MD but is not required. In applications where the supply pressure is higher than the maximum actuator pressure rating a supply regulator is required to lower the pressure to the actuator's maximum rating (not to be confused with operating range). An air filter is highly recommended for all applications where dirty air is a possibility.

NOTE: The air supply must conform to ISA Standard ISA 7.0.01 (a dew point at least 18°F below ambient temperature, particle size below five microns—one micron recommended—and oil content not to exceed one part per million).

Air-to-open and air-to-close are determined by the actuator tubing, not the software. When air action selection is made during configuration, that selection tells the control which way the actuator has been tubed. The top output port is called *Output 1*. It should be tubed to the side of the actuator that must receive air to begin the correct action on increasing signal. Verify that tubing is correct prior to a stroke calibration. Proper tubing orientation is critical for the positioner to function correctly and have the proper failure mode. Refer to Figure 1 and follow the instructions below:

Linear Double-acting Actuators

For a linear air-to-open actuator, the Output 1 port of the positioner manifold is tubed to the bottom side of the actuator. The Output 2 port of the positioner manifold is tubed to the top side of the actuator. For a linear air-to-close actuator the above configuration is reversed.

Rotary Double-acting Actuators

For a rotary actuator, the Output 1 port of the positioner manifold is tubed to the bottom side of the actuator. The Output 2 port of the positioner manifold is tubed to the top side of the actuator. This tubing convention is followed regardless of air action. On rotary actuators, the transfer case orientation determines the air action.

Single-acting Actuators

For single-acting actuators, the Output 1 port is always tubed to the pneumatic side of the actuator regardless of air action. The Output 2 port must be plugged.

Figure 6: Field Termination

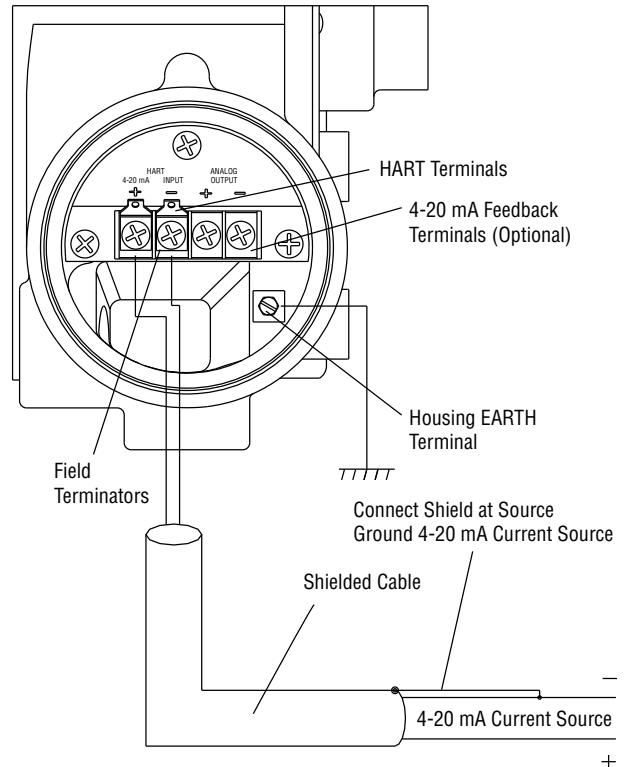

6 Wiring and Grounding Guidelines (See Figure 6)

⚠ **WARNING:** This product has electrical conduit connections in either thread sizes ½" NPT or M20 which appear identical but are not interchangeable. Housings with M20 threads are stamped with the letters M20 above the conduit opening. Forcing dissimilar threads together will damage equipment, cause personal injury and void hazardous location certifications. Conduit fittings must match equipment housing threads before installation. If threads do not match, obtain suitable adapters or contact a Flowserve representative.

6.1 4-20 mA Command Input Wiring

Verify polarity when making field termination connection. The Logix 3200 is reverse polarity protected. Wire 4-20 mA current source to the input terminal labeled 4-20 mA Input on the user interface board (see Figure 6). Never connect a voltage source directly across the Logix 3200MD terminals. The current must always be limited for 4-20 mA operation. Minimum operating current is 3.6 mA.

The input loop current signal to the Logix 3200MD digital positioner should be in shielded cable. Shields must be tied to a ground at only one end of the cable to provide a place for environmental electrical noise to be removed from the cable. In general, shield wire should be connected at the source.

NOTE: The Logix 3200MD positioner carries an intrinsically safe barrier rating of 100 mA. Input currents should not exceed 100 mA.

6.2 Grounding Screw

The green grounding screw, located inside the termination cap, should be used to provide the unit with an adequate and reliable earth ground reference. This ground should be tied to the same ground as the electrical conduit. Additionally, the electrical conduit should be earth grounded at both ends of its run.

⚠ **WARNING:** The green grounding screw must not be used to terminate signal shield wires.

6.3 Compliance Voltage (See Figure 7)

Output compliance voltage refers to the voltage limit that can be provided by the current source. A current loop system consists of the current source, wiring resistance, barrier resistance (if present), and the Logix 3200MD positioner impedance. The Logix 3200MD digital positioner requires that the current loop system allows for a 10.0 VDC drop across the positioner at maximum loop current. The 10.0 VDC drop across the Logix 3200MD positioner terminals is generated by the positioner from the 4-20 mA loop current input.

Figure 7: Compliance Voltage

The actual voltage at the terminals varies from 9.8 to 10.0 VDC depending on the current mA signal, HART communications, and ambient temperature.

⚠ **WARNING:** Never connect a voltage source directly across the positioner terminals. This could cause permanent circuit board damage.

Determine if the loop will support the Logix 3200MD digital positioner by performing the following calculation.

$$\text{Voltage} = \text{Compliance Voltage (@Current}_{\text{max}}) - \text{Current}_{\text{max}} \cdot (R_{\text{barrier}} + R_{\text{wire}}) \quad \text{Equation 1}$$

The calculated voltage must be greater than 10 VDC in order to safely support the Logix 3200MD digital positioner.

Example:

DCS Compliance Voltage = 19 VDC

$R_{\text{barrier}} = 300 \Omega$

$R_{\text{wire}} = 25 \Omega$

$\text{Current}_{\text{max}} = 20 \text{ mA}$

$\text{Voltage} = 19 \text{ VDC} - 0.020 \text{ A} \cdot (300 \Omega + 25 \Omega) = 12.5 \text{ VDC}$

The voltage 12.5 VDC is greater than the required 10.0 VDC; therefore, this system will support the Logix 3200MD digital positioner. The Logix 3200MD positioner has a worst case input resistance equivalent to 500 Ω at a 20 mA input current.

6.4 Cable Requirements

The Logix 3200MD digital positioner utilizes the HART Communication protocol. This communication signal is superimposed on the 4-20 mA current signal. The two frequencies used by the HART protocol are 1200 Hz and 2200 Hz. In order to prevent

distortion of the HART communication signal, cable capacitance and cable length restrictions must be calculated. The cable length must be limited if the capacitance is too high. Selecting a cable with lower capacitance/foot rating will allow longer cable runs. In addition to the cable capacitance, the network resistance also affects the allowable cable length.

In order to calculate the maximum network capacitance, use the following formula:

$$C_{\text{network}} (\mu\text{F}) \leq \left[\frac{65}{(R_{\text{barrier}} + R_{\text{wire}} + 390)} \right] - 0.0032 \quad \text{Equation 2}$$

Example: $R_{\text{barrier}} = 300 \Omega$
 $R_{\text{wire}} = 50 \Omega$
 $C_{\text{cable}} = \frac{22 \text{ pF}}{\text{foot}} = 0.000022 \mu\text{F}/\text{foot}$

$$\left[\frac{65}{(300 + 50 + 390)} \right] - 0.0032 = 0.08 \mu\text{F} = C_{\text{max network}} (\mu\text{f})$$

$$\text{Maximum Cable Length} = \frac{C_{\text{max network}} (\mu\text{F})}{C_{\text{cable}}}$$

$$\text{Maximum Cable Length} = \frac{0.08 \mu\text{F}}{0.000022 \mu\text{F}/\text{foot}} = 3636 \text{ ft.}$$

To control cable resistance, 24 AWG cable should be used for runs less than 5000 feet. For cable runs longer than 5000 feet, 20 AWG cable should be used.

6.5 Intrinsically Safe Barriers

When selecting an intrinsically safe barrier, make sure the barrier is HART compatible. Although the barrier will pass the loop current and allow normal positioner control, if not compatible, it may prevent HART communication.

7 Startup

7.1 Logix 3200MD Local Interface Operation

The Logix 3200MD local user interface allows the user to configure the basic operation of the positioner, tune the response, and calibrate the positioner without additional tools or configurators. The Local interface consists of a quick calibration button for automatic zero and span setting, along with two jog buttons for spanning valve/actuators with no fixed internal stop in the open position. There is also a switch block containing 8 switches. Six of the switches are for basic configuration settings and one is for calibration options. There is also a gain selector switch for adjusting the positioner gain settings. For indication of the operational status or alarm conditions there are also 3 LEDs on the local user interface.

Figure 8: Local User Interface

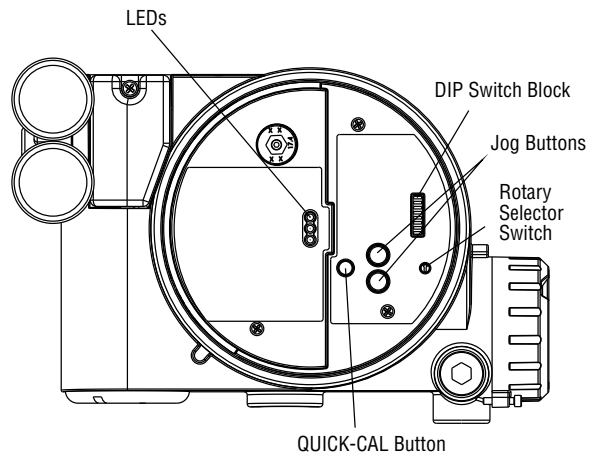

7.2 Initial DIP Switch Settings

Before placing the unit in service, set the dip-switches in the Configuration and Cal boxes to the desired control options. For a detailed description of each dip-switch setting, see sections 1&2.

NOTE: The switch settings in the Configuration box are activated only by pressing the “Quick Cal” button, except Auto-tune adjustments that can be made at any time.

7.3 Operation of Configuration DIP Switch Settings

The first 7 Dip Switches are for basic configuration

Air Action

This must be set to match the configuration of the valve/actuator mechanical tubing connection and spring location since these determine the air action of the system.

ATO (air-to-open) Select ATO if increasing output pressure from the positioner port 1 is tubed so it will cause the valve to open.

ATC (air-to-close) Select ATC if increasing output pressure from the positioner port 1 is tubed so it will cause the valve to close.

Signal at Closed

Normally this will be set to 4 mA for an Air-to-open actuator, and 20 mA for an Air-to-close actuator configuration.

4 mA Selecting 4 mA will make the valve fully closed when the signal is 4 mA and fully open when the signal is 20 mA.

20 mA Selecting 20 mA will make the valve fully closed when the signal is 20 mA and fully open when the signal is 4 mA.

Figure 9: Default Custom Characterization

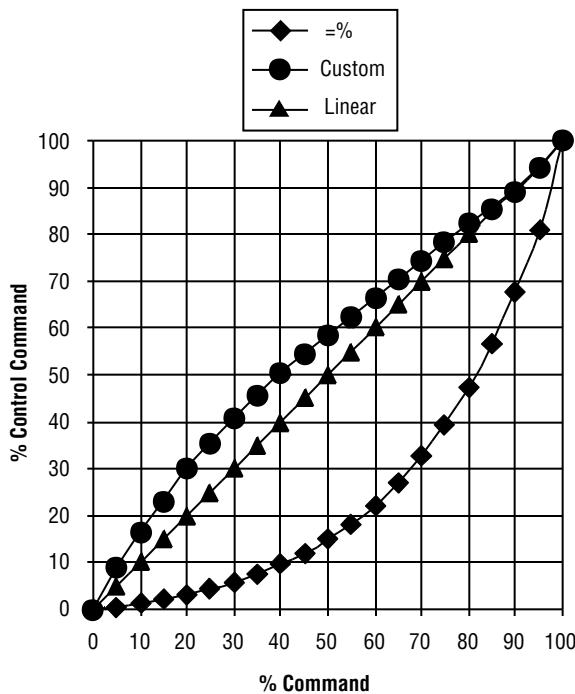

Pos. Characterization

Linear Select if the actuator position should be directly proportional to the input signal. (Due to their inherent =% characteristics, this setting give an =% Cv characteristic for most rotary valves.)

Optional Select if another characteristic is desired, which is set in conjunction with the next switch, labeled Optional Pos. Char.

Optional Pos. Characterization

If the Pos. Characterization switch is set to optional then this switch is active with the following options:

The =% option will characterize the actuator response to the input signal based on a standard 30:1 equal percent rangability curve

Custom If *Custom* is selected, the positioner will be characterized to a custom table that must be set-up using a properly configured HART 275 handheld or other host software. The Default setting for this curve is modified quick open. (also used for a linear Cv characteristic for most rotary valves)

Table VIII: Characteristic Curve Data

% Command	% Control Command		
	=%	Linear	Custom
0	0	0	0
5	0.62	5	8.66
10	1.35	10	16.24
15	2.22	15	23.17
20	3.25	20	30.11
25	4.47	25	35.31
30	5.91	30	40.51
35	7.63	35	45.42
40	9.66	40	50.34
45	12.07	45	54.40
50	14.92	50	58.47
55	18.31	55	62.39
60	22.32	60	66.31
65	27.08	65	70.27
70	32.71	70	74.23
75	39.40	75	78.17
80	47.32	80	82.11
85	56.71	85	85.50
90	67.84	90	88.89
95	81.03	95	94.45
100	100.00	100	100.00

Auto Tune

This switch controls whether the positioner will auto tune itself or use preset tuning parameters.

On *On* enables an auto tune feature that will automatically determine the positioner gain settings based on the current position of the selectable “Gain” switch setting and response parameters measured during the last Quick-Cal. The gain switch is live meaning the settings can be adjusted at any time by changing the selectable gain switch position. (Note that there is a small black arrow indicating the selection. The slot is NOT in the indicator.)

Figure 10: Adjustable GAIN Switch



If the selectable GAIN switch is set to “D”, “C”, or “B”, with the auto tune switch on, progressively lower gain settings will be used based on response parameters measured during the last QUICK-CAL.

If the adjustable GAIN selector switch is set to “F”, “G”, or “H” with the auto tune switch on, progressively higher gain settings will be calculated and used based on response parameters measured during the last QUICK-CAL.

If the selectable GAIN switch is set to “A” the tuning will not be modified with a QUICK-CAL. Use this setting if custom tuning will be done using a handheld or other Flowserve software.

Off *Off* forces the positioner to use one of the factory preset tuning sets determined by the rotary “Gain” selector switch. Settings “A” through “H” are progressively higher gain predefined tuning sets. The Gain selector switch can be adjusted at any time to modify the tuning parameters.

NOTE: With Autotune on “E” is the default adjustable GAIN selector switch setting for all actuator sizes. Raising or lowering the gain setting is a function of the positioner/valve response to the control signal, and is not actuator size dependent.

Spare Switch

If special features have been purchased they may be controlled by this switch. See special documentation for more details.

Stability Switch

This switch adjusts the position control algorithm of the positioner for use with low-friction control valves or high-friction automated valves.

Placing the switch to the left optimizes the response for low friction, high performance control valves. This setting provides

for optimum response times when used with most low friction control valves.

Placing the switch to the right optimizes the response for valves and actuators with high friction levels. This setting slightly slows the response and will normally stop limit cycling that can occur on high friction valves.

NOTE: This option is more effective on advanced units with the optional pressure sensors installed.

7.4 Setup of the Cal Dip-Switch for the Quick Calibration operating mode.

The eighth DIP switch selects between two calibration options. The function of the Cal DIP switch is described below.

Auto Select *Auto* if the valve/actuator assembly has an internal stop in the open position. In Auto mode the positioner will fully close the valve and register the 0% position and then open the valve to the stop to register the 100% position when performing a self-calibration. See detailed instructions in the next section on how to perform an auto positioner calibration.

Jog Select *Jog* if the valve/actuator assembly has no calibration stop in the open position. In the Jog mode the positioner will fully close the valve for the 0% position and then wait for the user to set the open position using the Jog buttons labeled with the up and down arrows. See the detailed instructions in the next section on how to perform a manual calibration using the “Jog” buttons.

⚠ WARNING: During the QUICK-CAL operation the valve may stroke unexpectedly. Notify proper personnel that the valve will stroke, and make sure the valve is properly isolated.

7.5 QUICK-CAL Operation

The QUICK-CAL button is used to locally initiate a calibration of the positioner. Pressing and holding the QUICK-CAL button for approximately 3 seconds will initiate the calibration. A QUICK-CAL can be aborted at any time by briefly pressing the QUICK-CAL button and the previous settings will be retained.

If the Quick calibration switch (be careful not to confuse with the QUICK-CAL button) is set to Auto and the valve/actuator assembly has the necessary internal stops the calibration will complete automatically. While the calibration is in progress you will notice a series of different lights flashing indicating the calibration progress. When the lights return to a sequence that starts with a green light the calibration is complete. (see the table X for an explanation of the various light sequences) The initial calibration of extremely large or very small actuators may require several calibration attempts. The positioner adapts to the actuator performance and begins each

calibration where the last attempt ended. On an initial installation it is recommended that after the first successful calibration that one more calibration be completed for optimum performance.

If the Quick calibration switch is set to Jog, the calibration will initially close the valve then cause a small jump in the valve position. The jog calibration process will only allow the user to manually set the span; zero position is automatically always set at the seat. If an elevated zero is needed a handheld or other PC based configuration software is required. When performing a jog calibration the LED's will flash in a sequence of Y-G-Y-R (yellow-green-yellow-red) which indicates that the user must use the jog keys to manually position the valve to approximately 100%. When the valve is approximately 100% open press both the ▲ and ▼ buttons simultaneously to proceed to the next step. The valve will then stroke and then wait while flashing the Y-G-Y-R sequence again, allowing the user to adjust the valve position a second time to exactly 100% using the jog buttons. When the stem is properly positioned press both the ▲ and ▼ buttons simultaneously again to register the 100% position and proceed. No more user actions are required while the calibration process is completed. When the lights return to a sequence that starts with a green light the calibration is complete. (see the appendix for an explanation of the various light sequences)

7.6 Local control of valve position

Local control of valve position can be done from the user interface by holding both jog buttons while then simultaneously pressing the quick cal button for 3 seconds. The ▲ and ▼ buttons can then be used to position the valve. While in this mode the LED's will flash a YGY (yellow-green-yellow) sequence. To exit the local control mode and return to normal operation, briefly press the quick-Cal button.

⚠ **WARNING:** When operating using local control of the valve, the valve will not respond to external commands. Notify proper personnel that the valve will not respond to remote command changes, and make sure the valve is properly isolated

7.7 Factory Reset

To perform a factory reset, hold QUICK-CAL button while applying power and all of the internal variables including calibration will be reset to factory defaults. The positioner must be re-calibrated after a factory reset. Tag names and other user configured limits, alarm settings, and valve information will also be lost and need to be restored.

⚠ **WARNING:** Performing a factory reset may result in the inability to operate the valve until reconfigured properly. Notify proper personnel that the valve may stroke, and make sure the valve is properly isolated.

7.8 Command Reset

Performing a command reset will reset the command source to analog if it has been inadvertently left in digital mode. This is done while a QUICK-CAL is in process by holding down both the ▲ and ▼ buttons while briefly pressing the QUICK-CAL button. A new QUICK-CAL must be done after resetting.

7.9 Version number checking

The version number of the embedded code may be checked at any time except during a calibration by holding down the ▲ button. This will not alter the operation of the unit other than to change the blink sequence to 3 blinks indicating the major version number. Holding the ▼ button will give the minor version number without affecting operation. The version codes are interpreted by adding up the numbers assigned according to the following table:

Table IX: Version number checking

Color	First Blink Value	Second Blink Value	Third Blink Value
Green	0	0	0
Yellow	9	3	1
Red	18	6	2

For example if holding the ▲ button gave a G-G-R code, and holding the ▼ button gave a Y-Y-G code then the resulting version number would be (0+0+2).(9+3+0) or version 2.12.

7.10 Logix 3200MD Status Condition

The blink codes used to convey the status of the Logix 3200MD digital positioner are described in the following table. In general, any sequence starting with a green light flashing first is a normal operating mode and indicates that there are no internal problems.

Some diagnostic status results are only available with the Advanced or Pro diagnostics option.

Table X: Logix 3200MD Status Condition Codes

Blink Code	Description	Recommendations
GGGG	NORMAL OPERATION indicates normal, healthy operation	
GGGY	MPC ACTIVE MODE (user set) indicates that tight shutoff (MPC) is active. The command is beyond the user set limit for tight shutoff feature. This is a normal condition for all valves when closed. The factory default setting triggers this at command signals below 1%. This indication may also occur on 3 way valves at both ends of travel if the high MPC value has been set.	If tight shutoff is not desired reset the tight shutoff limits to the correct values or adjust the command signal inside of the specified MPC value. See DTM screen: Configuration/Custom/Position Cutoff.
GGYG	LOCAL INTERFACE DISABLED/ENABLED when DISABLED, indicates PC software has been used to disable the local interface. This code is only present for a short time when the Quick Cal button is pressed.	If local control is desired then the local interface must be re-enabled from the remote software. See DTM screen: Configuration/Basic Local Interface.
GGYY	DIGITAL COMMAND SOURCE indicates a HART signal is needed to change the position command and the analog 4-20 mA input signal is ignored.	A manual Command Source Reset is provided to change the command back to analog control mode from the local interface if a PC or hand held configurator is not available. This is done while a QUICK-CAL is in progress by holding down both the Jog buttons (up and down) while briefly pressing the QUICK-CAL button. A new QUICK-CAL must be done after resetting. See DTM screen: Dashboard.
GRRR	SQUAWK MODE ON/OFF (user set) When ON, this indicates a user has set the positioner to flash a special sequence so that it can be visually located.	This mode is canceled if the Quick-cal button is briefly pressed, the Squawk mode is selected again remotely, or more than one hour has passed since the command was issued. See DTM screen: Configuration/Custom/LED.
GYGG	POSITION LIMIT ALERT (user set) indicates the position has reached or is exceeding a user defined upper or lower position indicator similar to a limit switch indicator.	Reset the indicator if more travel is needed or adjust the command signal back in the specified range. See DTM screen: Configuration/Custom/Position Cutoff. This indicator can be disabled.
GYGY	SOFT STOP LIMIT ALERT (user set) indicates the unit is being commanded to exceed a user defined upper or lower position limit and the internal software is holding the position at the limit. The function is similar to a mechanical limit stop except it is not active if the unit is un-powered.	Reset the limit if more travel is needed or adjust the command signal back in the specified range. See DTM screen: Configuration/Custom/Soft Limits.
GRGG	CYCLES or TRAVEL LIMIT ALERT (user set) indicates that one of the cycle or travel limits has been exceeded. The criterion and count limit are set by the user to track the usage of the valve. There are accumulators for total valve travel, total valve cycles, total spool valve travel, and total spool valve cycles. Flowserve supplies software can identify the specific limit that has been reached.	For valve accumulators indications follow routine procedures for maintenance when the limit is reached such as checking the packing tightness, and checking linkages for wear, misalignment, and tightness. After maintenance, reset the cycle accumulator. See DTM screen: Health Status/Positioner Health. This indicator can be disabled. For spool valve accumulators inspect for high air consumption and signs of wear. See DTM screen: Health Status/Positioner Health. This indicator can be disabled.
YGGY	SIGNATURE IN PROGRESS MODE indicates that a test has been initiated by Flowserve supplied software	Signatures can only be canceled by Flowserve supplied software. See DTM screen: Diagnostics.
YGGR	INITIALIZING MODE displays a blink sequence 3 times when the unit is powering up.	Wait for power up to complete.
YGYG	CALIBRATION IS IN PROGRESS indicates a calibration is process. Calibrations such as stroke may be initiated locally with the Quick-Cal button or remotely. Other calibrations for the inputs and outputs or pressure sensors are only initiated remotely.	Local calibration may be canceled by briefly pushing the quick-cal button. Remote calibrations can only be canceled by the software.
YGY Y	JOG COMMAND STATE indicates the unit has been placed in a local override mode where the valve can only be stroked using the two local jog buttons.	Control the valve using the jog buttons. This mode may be canceled by briefly pushing the quick-cal button.
YGYR	JOG CALIBRATION STATE indicates that during a jog calibration, the unit is waiting for the user to manually adjust the valve position to the desired 100% open position.	Use the buttons on the positioner to adjust the valve to the desired fully open position. See the explanation of Jog Calibrate in the Quick-Cal section of main document for operation.
YYGG	POSITIONER TEMPERATURE WARNING (user set) indicates the internal electronics have exceeded a temperature limit. The minimum limit of the electronics and the default setting is -40°F (-40°C). Low temperature may inhibit responsiveness and accuracy. The maximum limit of the electronics and default setting is 185°F (85°C). High temperature may limit the life of the positioner.	Regulate the temperature of the positioner. If the temperature reading is in error, replace the main board. See DTM screen: Health Status/Positioner Health. This indicator can be disabled.
YYGY	PRESSURE OUT OF RANGE WARNING indicates that during a pressure sensor calibration, the range of applied pressures to port 1 was too small for optimum performance.	Adjust the supply pressure to a proper value (30-150 psig) so the positioner can properly calibrate the sensors. Then recalibrate. Briefly push the quick-cal button to acknowledge this condition and the positioner will operate using the current short stroke calibration values if valid.

Blink Code	Description	Recommendations
YYGR	SUPPLY PRESSURE HIGH WARNING indicates the positioner has determined that the supply pressure is above the user set warning limit.	Regulate the supply pressure at the positioner below the maximum limit recommended for your actuator. Recalibrate pressure sensors. Check the pressure sensor board connections. Replace pressure sensor board if necessary. See DTM screen: Health Status/Actuator Health. This indicator can be disabled.
YYYG	SUPPLY PRESSURE LOW WARNING (user set) indicates that the supply pressure is below the user set warning limit. Low supply pressure can cause poor valve response or positioner failure. The minimum recommended supply pressure is 30 PSI (2.1 bar) for proper operation. The unit will fail at less than approximately 17 PSI (1.2 bars). Low supply pressure indications can also be caused by pneumatic leak.	Regulate the supply pressure at the positioner above 30 PSI (2.1 bar). Recalibrate pressure sensors. Ensure system air/gas supply is adequate. Repair kinked supply tubing. Check the pressure sensor board connections and replace pressure sensor board if necessary. Check for pneumatic leaks in the actuator and actuator tubing. See DTM screen: Health Status/Actuator Health. This indicator can be disabled.
YYYY	ACTUATION RATIO WARNING (user set) indicates a decreased ability of the system to actuate the valve. It is based on the ratio of available force to required force to actuate. It is affected by the process load, friction, spring force, and available supply pressure.	Increase the supply pressure. Reduce the friction. Check the actuator spring. Resize the actuator. Adjust user set limits. See DTM screen: Health Status/Actuator Health. This indicator can be disabled.
YRGG	PILOT RELAY RESPONSE WARNING (user set) indicates that the pilot relay is sticking or slow to respond. This affects the responsiveness, increases the chance of limit cycling and excessive air consumption. The pilot relay is part of the inner loop and consists of the driver module assembly with piezo (I-P relay) which is coupled to the spool valve. The value of this indicator corresponds with inner loop lag. Delayed response can be caused by a partially clogged piezo or debris, oil, corrosion, or ice on the spool, or low supply pressure.	Check response of the valve. If OK, adjust Pilot Relay Response limits. Check supply pressure. Check the spool for debris, oil, corrosion, ice on the spool. Clean or replace the spool assembly. Replace the piezo or driver module assembly. Maintain a clean, water-free air/gas supply. See DTM screen: Health Status/Positioner Health. This indicator can be disabled.
YRGY	FRICTION LOW WARNING (user set) indicates the friction has passed below the user set limit.	Low friction is usually an indication of improperly loaded packing or seals in the valve and actuator. See DTM screen: Health Status/Valve Health. This indicator can be disabled.
YRGR	PNEUMATIC LEAK WARNING (user set) indicates that the positioner has detected a leak in the actuation assembly. Leakage from the actuator can cause decreased responsiveness and excessive air/gas consumption. Low supply pressure can also trigger this warning.	Repair pneumatic leaks at the tubing junctions and actuator seals. Ensure proper supply pressure. See DTM screen: Health Status/Actuator Health. This indicator can be disabled.
YRYG	FRICTION HIGH WARNING (user set) indicates the valve/actuator friction has passed the user set limit. High friction can cause loop oscillations, poor position control, jerky motion, or valve sticking. It can be caused by build-up from the process on the stem, trim or seat, by a failing bearing or guides in the valve and actuator, galling of the trim or stem, excessively tightened packing, linkages, or other valve/actuator mechanical issues.	Determine if the friction is significantly interfering with the valve control. If not, consider increasing the friction warning limit. Consider the following to reduce friction: Stroke the valve to clear off build-up. Clear any external mechanical obstruction, loosen the packing, clean the stem, repair or replace the actuator. Highly localized friction or very jerky travel can indicate internal galling. Repair or replace internal valve components. See DTM screen: Health Status/Valve Health. This indicator can be disabled.
YRRY	ELECTRONIC INABILITY TO FAIL SAFE WARNING indicates that the piezo may be damaged. This may prevent the proper failure position upon loss of signal/power. This condition may occur briefly on an air-to-close valve that is held for long periods of time in the closed position, or and air-to-open valve held in the open position.	If alarm persists for more than 30 minutes, the Piezo assembly is damaged and should be replaced. This indicator can be disabled.
YRRR	PNEUMATIC INABILITY TO FAIL SAFE WARNING indicates that upon loss of air supply, the valve may not move to the fail-safe position. The spring alone is not adequate to overcome the friction and process load in the system. The system is relying on pneumatic force to actuate in the direction the spring is pushing. The failsafe spring may have failed, or it was not sized properly for the application. Friction or process load may have increased.	Check for high friction. Repair or replace actuator spring. Reduce process load. This indicator can be disabled.
RGGY	FEEDBACK READING PROBLEM DURING CALIBRATION ALARM indicates that during calibration, the range of motion of the position feedback arm was too small for optimum performance, or the position sensor was out of range.	Check for loose linkages and/or adjust the feedback pin to a position closer to the follower arm pivot to create a larger angle of rotation if the feedback rotation is less than 15 degrees for the total valve travel and recalibrate. Briefly pushing the quick-cal button acknowledges this condition and the positioner will operate using the current short stroke calibration if otherwise a good calibration. If the condition does not clear then adjust the positioner mounting, linkage or feedback potentiometer to move the position sensor back into range then restart the calibration. This error may be cleared by briefly pushing the quick-cal button, which will force the positioner to use the parameters from the last good calibration.

Blink Code	Description	Recommendations
RGGR	INNER LOOP OFFSET TIME OUT ALARM during calibration the Inner Loop Offset value did not settle. This could result in less accurate positioning.	Repeat the stroke calibration to get a more accurate ILO value. To proceed using the less accurate ILO value, this error may be cleared by briefly pushing the quick-cal button. Lowering the gain setting may help if the actuator is unstable during the calibration. Gain settings can be physically adjusted on the device. A lower letter represents lower gain.
RGYG	NON-SETTLE TIME OUT ALARM indicates that during calibration, the position feedback sensor did not settle.	Check for loose linkages or a loose positioner sensor. This error may be cleared by briefly pushing the quick-cal button, which will force the positioner to use the parameters from the last good calibration. This error may appear on some very small actuators during the initial calibration. Recalibrating may clear the problem.
RGYY	NO MOTION TIME OUT ALARM indicates that during calibration, there was no motion of the actuator based on the current stroke time configuration.	Check linkages and air supply to make sure the system is properly connected. If the time out occurred because the actuator is very large then simply retry the Quick cal and the positioner will automatically adjust for a larger actuator by doubling the time allowed for movement. This error may be cleared by briefly pushing the quick-cal button, which will force the positioner to use the parameters from the last good calibration.
RGRR	FACTORY RESET STATE indicates the unit has had a factory reset and has not yet been calibrated. The unit will not respond to commands and will remain in the failsafe position until a calibration is successfully completed.	Calibrate. Proper Valvesight operation will require stroke, actuator, and friction calibration to be completed. This indicator can be disabled.
RYYG	SUPPLY PRESSURE LOW ALARM (user set) indicates that the supply pressure is below the user set alarm limit. Low supply pressure can cause poor valve response or positioner failure. The minimum recommended supply pressure is 30 PSI (2.1 bar) for proper operation. The unit will fail at less than approximately 17 PSI (1.2 bars). Low supply pressure indications can also be caused by pneumatic leak.	Regulate the supply pressure at the positioner above 30 PSI (2.1 bar). Recalibrate pressure sensors. Ensure system air/gas supply is adequate. Repair kinked supply tubing. Check the pressure sensor board connections and replace pressure sensor board if necessary. Check for pneumatic leaks in the actuator and actuator tubing. See DTM screen: Health Status/Actuator Health.
RRGG	PILOT RELAY RESPONSE ALARM (user set) indicates that the pilot relay is sticking or extremely slow to respond. This affects the responsiveness, increases the chance of limit cycling and excessive air consumption. The pilot relay consists of the driver module assembly with piezo (I-P relay) which is coupled to the spool valve. Delayed response can be caused by a partially clogged piezo or debris, oil, corrosion, or ice on the spool, or low supply pressure.	Check response of the valve. If OK, adjust Pilot Relay Response limits. Check the supply pressure. Check the spool for debris, oil, corrosion, ice on the spool. Clean or replace the spool assembly. Replace the piezo or driver module assembly. Maintain a clean, water-free air/gas supply. See DTM screen: Health Status/Positioner Health. This indicator can be disabled.
RRGY	FRICTION LOW ALARM (user set) indicates the friction has passed below the user set limit. The alarm indicates a more severe condition than the warning.	Check for a packing leak. Tighten or replace the valve packing. See DTM screen: Health Status/Valve Health. This indicator can be disabled.
RRGR	FRICTION HIGH ALARM (user set) indicates the valve/actuator friction has passed the user set limit. The alarm indicates a more severe condition than the warning. High friction can cause loop oscillations, poor position control, jerky motion, or valve sticking. It can be caused by build-up from the process on the stem, trim or seat, by a failing bearing or guides in the valve and actuator, galling of the trim or stem, excessively tightened packing, linkages, or other valve/actuator mechanical issues.	Determine if the friction is significantly interfering with the valve control. If not, consider increasing the friction warning limit. Consider the following to reduce friction: Stroke the valve to clear off build-up. Clear any external mechanical obstruction, loosen the packing, clean the stem, repair or replace the actuator. Highly localized friction or very jerky travel can indicate internal galling. Repair or replace internal valve components. See DTM screen: Health Status/Valve Health This indicator can be disabled.
RRYG	PIEZO VOLTAGE ALARM indicates the portion of the circuit board that drives the piezo is bad, or piezo valve itself is bad.	If the unit is functioning and controlling replace the piezo, if it does not operate replace the main circuit board. This indicator can be disabled.
RRYR	PILOT RELAY POSITION LIMIT ALARM indicates the pilot relay (spool) appears to be fixed at a limit and is not responding. This could be due to low supply pressure, a hall sensor that is out of calibration, a broken piezo, stuck spool, or a wire connection problem.	Check for adequate supply pressure. A hall sensor problem may be cleared by briefly pushing the quick-cal button, which will force the positioner to use the parameters from the last valid calibration. Check the internal wiring harnesses for good connections. Check the spool valve for sticking problems. If the positioner still does not operate replace the piezo, driver module assembly, and/or spool assembly.
RRRY	ELECTRONICS ERROR OR ALARM indicates the internal data was not updated correctly. This may affect the function of the positioner in various ways or not at all. This can be caused when intermittent operation occurs when connecting power.	Error may self clear with time. If error persists, cycle power and complete a Quick-Cal. If the error still persists, Check internal wiring and connectors for electrical shorts or opens. If no problems are found and alarm persists, replace the main circuit board.
RRRR	POSITION DEVIATION ALARM (user set) indicates the difference between the command and the actual position has been greater than the user-set limit for longer than a user-set time.	Review active alarms and warnings to find root causes of this alarm. See DTM screen: Alerts/Command Deviation. This indicator can be disabled.

7.11 ValveSight Configuration and Diagnostic Software and HART 375 Handheld Communicator

Flowserve Corporation has written custom configuration and diagnostic software for the Logix 3200MD digital positioner called *ValveSight*. This software is available from a Flowserve representative.

The Logix 3200MD digital positioner supports and is supported by the HART 375 Handheld Communicator. The Device Description (DD) files and the manual listed below can be obtained from the HART Communication Foundation or from your Flowserve representative. For more information please see the following guide:

- Product Manual for the HART Communicator.

Diagnostic features such as the datalog, signature tests, and ramp tests are performed using the ValveSight software. Certain calibration features such as loop calibration, analog output calibration, and actuator pressure sensor calibrations are performed using the HART 375 Handheld Communicator or using diagnostic software such as ValveSight.

8 Maintenance and Repair

8.1 Driver Module Assembly

The driver module assembly moves the spool valve by means of a differential pressure across its diaphragm. Air is routed to the driver module from the regulator through a flexible hose. A barbed fitting connects the flexible hose to the driver module assembly. Wires from the driver module assembly connect the hall effect sensor and the piezo valve modulator to the main PCB assembly.

Driver Module Assembly Replacement

To replace the driver module assembly, refer to Figures 11-15 and 25 and proceed as outlined below. The following tools are required:

- Flat plate or bar about 1/8" thick
- Phillips screwdriver
- 1/4" nutdriver

⚠ **WARNING:** Observe precautions for handling electrostatically sensitive devices.

1. Make sure the valve is bypassed or in a safe condition.
2. Disconnect the power and air supply to the unit.

3. Remove the driver module cover (Figure 14), using a flat bar or plate in the slot to turn the cover.
4. Remove the spool valve cover by removing the screw and sliding the cover assembly backwards until the tab is clear of the slot (Figure 12). The sheet metal cap, hydrophobic filter, and O-ring should be removed with the spool valve cover. It is not necessary to take these parts out of the spool valve cover.
5. Being careful not to lose the nylon washer, remove the Phillips-head screw that attaches the driver module to the main housing (Figure 13).

⚠ **WARNING:** Spool (extending from the driver module assembly) is easily damaged. Use extreme caution when handling spool and spool valve block. Do not handle the spool by the machined portions of spool. The tolerances between the block and spool are extremely tight. Contamination in the block or on the spool may cause the spool to hang.

Figure 11: Driver Module Assembly

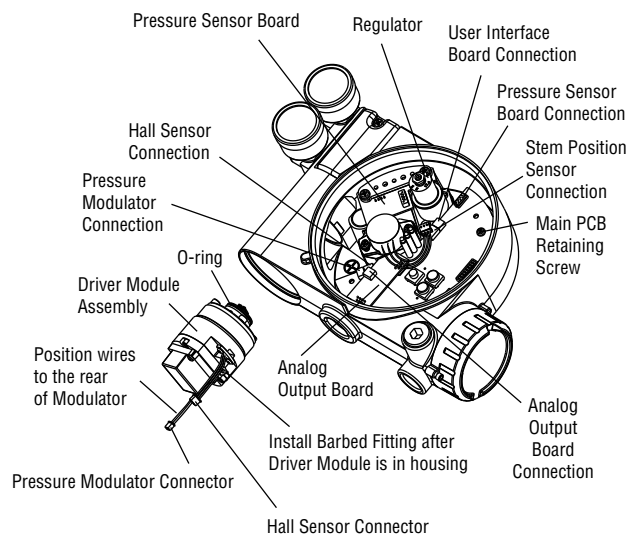

Figure 12: Spool Valve Cover Assembly

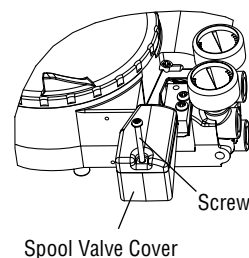

Figure 13: Spool and Block

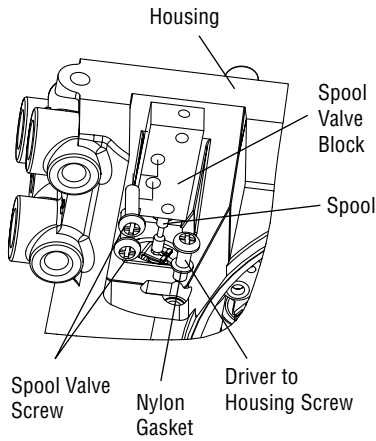
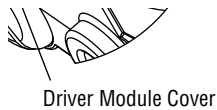

Figure 14: Driver Module Barbed Fitting



6. Remove the spool valve block by removing the two Phillips-head screws and carefully sliding the block off the spool (Figure 13).
7. Carefully remove the spool by sliding the end of the spool out of the connection clip. Excessive force may bend spool.
8. Remove the main cover.
9. Remove the plastic board cover by removing the three retaining screws (see Figure 14).
10. Disconnect the flexible tubing from the barbed fitting at the driver module assembly (see Figure 14).
11. Use the 1/4" nutdriver to remove the barbed fitting from the driver module assembly.
12. Unplug the two wiring connections that link the driver module assembly to the main PCB assembly.

13. Feed the two wires on the driver module back into the driver module compartment so that they stick out the driver module opening (see Figure 11). This will allow the driver module to thread out without tangling or cutting the wires.
14. Grasp the base of the driver module and turn it counterclockwise to remove. After it is threaded out, carefully retract the driver module from the housing.
15. Remove the barbed fitting from the side of the new driver module using the 1/4" nutdriver.
16. Verify that the O-ring is in place on the top of the new driver module. Lay the wires back along the side of the driver module as shown in Figure 11 and hold the wires in position by hand.
17. Gently insert the driver module into the driver module compartment in the housing. Turn the driver module clockwise to thread it into the housing. Continue rotating the driver module until it bottoms out.
18. Once the driver module has bottomed out so that the threads are fully engaged, rotate the driver module counter clockwise until the flat on the driver module and the flat on the housing are aligned. This will align the screw hole for the next step.
19. Verify that the nylon gasket is in the counter bore in the driver module retaining screw hole as shown in Figure 13.
20. Insert a driver-to-housing screw into the driver housing through the counterbored hole in positioner main housing. Tighten with a Phillips screwdriver.
21. Reach through the main compartment into the driver module compartment of the positioner and install the barbed fitting on the side of the driver module using the 1/4" nutdriver.

NOTE: Do not mix the barbed fitting with those from older Logix positioners. Older models contain orifices that will not work in the Logix 3200MD model. Orifices are brass-colored, barbed fittings are silver-colored.
22. Reconnect the flexible tube coming from the regulator to the barbed fitting.
23. Feed the driver module wires into the main chamber of the housing, and connect them to the main PCB Assembly.
24. Verify that the three O-rings are in the counterbores on the machined platform where the spool valve block is to be placed (Figure 25).
25. Carefully slide the spool into the connecting clip on the top of the driver module assembly.
26. Carefully slide the block over the spool, using the machined surface of the housing base as a register (Figure 13). Slide the

Figure 15: Main PCB Assembly

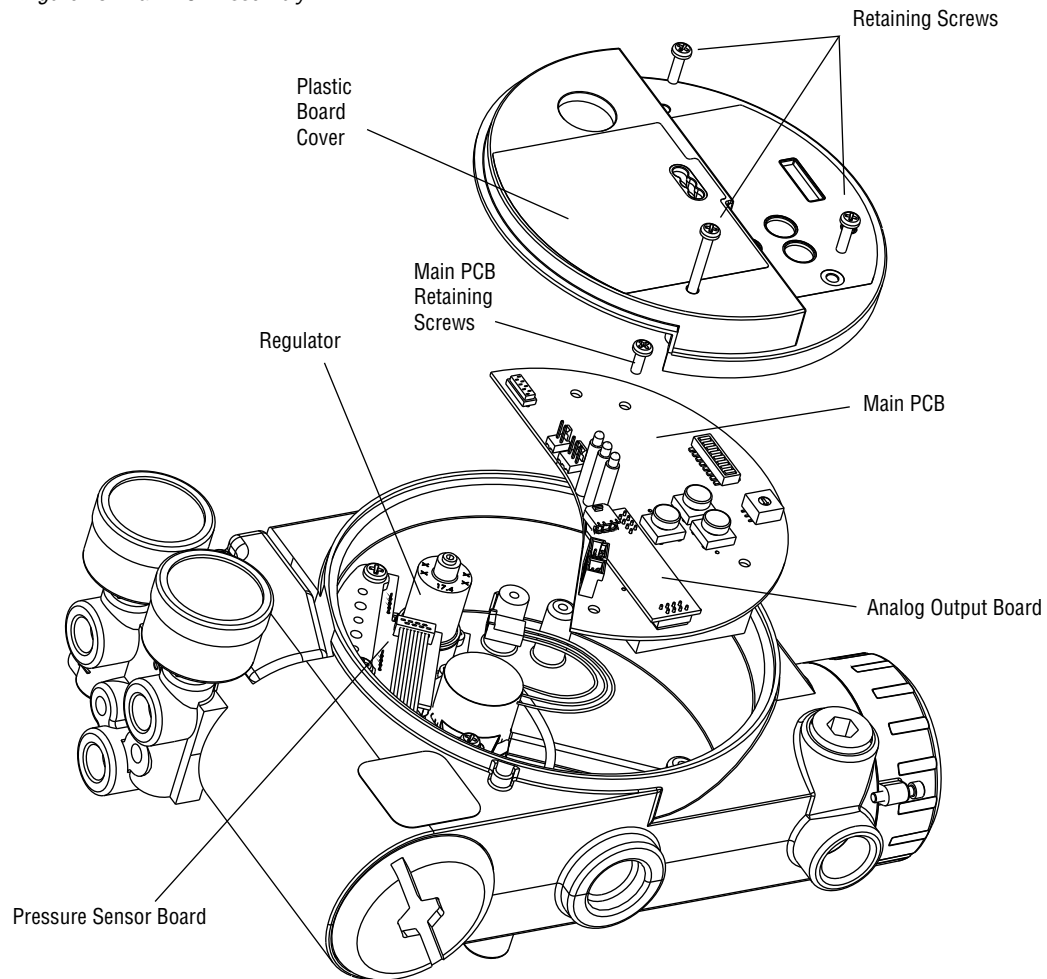

- block toward the driver module until the two retaining holes line up with the threaded holes in the base.
27. Install two spool-valve screws and tighten securely with a Phillips screwdriver (see Figure 13).
 28. Slide the spool valve cover assembly over the spool valve until the tang engages into the housing slot. Install spool valve cover screw and tighten securely (see Figure 12).
 29. Install the plastic board cover. Insert the three retaining screw through the plastic cover into the threaded boss and tighten evenly, using a Phillips screwdriver. Do not overtighten (see Figure 15).
 30. Reconnect power and air supply to the positioner and perform a stroke calibration.
 31. Reinstall all covers.

8.2 Regulator

The regulator reduces the pressure of the incoming supply air to a level that the driver module can use.

Replacing Regulator

To replace the regulator, refer to Figures 11 and 15 and proceed as outlined below. The following tools are required:

- Phillips screwdriver
- 1/4" nutdriver

⚠ **WARNING:** Observe precautions for handling electrostatically sensitive devices.

1. Make sure valve is bypassed or in a safe condition.
2. Disconnect the power and air supply to the unit.
3. Remove the main cover.
4. Remove the plastic board cover by removing the three retaining screws (see Figure 15).

5. Remove the five wire connections from the main PCB assembly (six wire connections if the unit is equipped with the 4-20 mA analog output option).
6. Remove the retaining screw from the main PCB assembly and lift the main PCB out of the housing.
7. Remove the four screws from the regulator base. Verify that as regulator is removed, the O-ring and filter remain in the counterbore (please see Figure 11).
8. Remove tubing and barbed fitting from the regulator base.
9. Install barbed fitting and tubing to the new regulator.
10. Verify O-ring and filter are in the counterbore. Install new regulator using 8-32 x 1/2" screws.

NOTE: Do not mix the regulator with those from older Logix positioners. Older models contain regulators with different settings that will not work in the Logix 3200MD model. The regulator pressure setting is printed on the top of the regulator. The Logix 3200MD regulator is set to 17.4 psig.

11. Install the main PCB into the housing. Insert the retaining screw through the board into the threaded boss and tighten evenly, using a Phillips screwdriver. Do not overtighten.
12. Reinstall the five wire connections (six wire connections if the unit is equipped with the 4-20 mA analog output option).
13. Install the plastic board cover. Insert the three retaining screws through the plastic cover into the threaded boss and tighten evenly, using a Phillips screwdriver. Do not overtighten (see Figure 15).
14. Reinstall all covers.

8.3 Checking or Setting Internal Regulator Pressure

To check or set the internal regulator pressure, refer to Figure 16 and proceed as outlined below. The tools and equipment used in the next procedure are from indicated vendors. The following tools are required:

- Calibrated pressure gauge (0 to 30 psi)
- 1/16" flexible tubing
- Barbed Tee (Clippard Minimatic part number T22-2 or equivalent)
- 3/32" Allen wrench
- 3/8" open-end wrench

⚠ WARNING: Observe precautions for handling electrostatically sensitive devices.

Figure 16: Driver Module Regulator Pressure Check

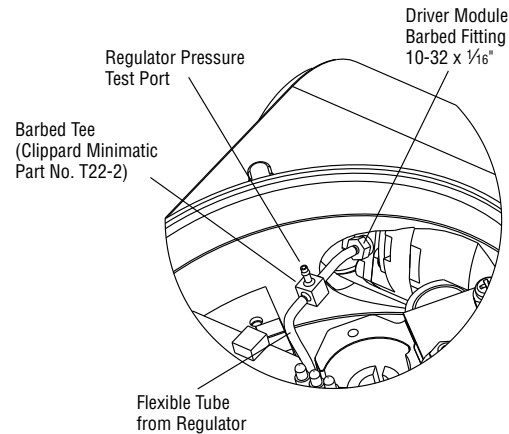

1. Make sure the valve is bypassed or in a safe condition.
2. Remove the main cover.
3. Remove the plastic board cover by removing the three retaining screws.
4. Remove the 1/16" flexible tubing from the barbed fitting on the side of the driver module.
5. Obtain a barbed tee and two pieces of 1/16" flexible tubing, a few inches in length each.
6. Position the barbed tee between the internal regulator and the driver module by connecting the 1/16" flexible tubing, found in the positioner, to one side of the barbed tee. Using one of the new flexible tubing pieces, connect the barbed tee to the barbed fitting on the side of the driver module. Connect the remaining port on the barbed tee to a 0 to 30 psi pressure gauge.
7. Reconnect the air supply to the positioner and read the internal regulator pressure on the 0 to 30 psig gauge. The internal pressure should be set to 17.4 ±0.2 psig. If adjustment is needed, loosen the set screw retaining nut on the top of the regulator using the 3/16" open-end wrench. Then adjust the regulator pressure by turning the set screw on the top of the regulator with the 3/32" Allen wrench.
8. Once the regulator pressure is set, tighten the set screw retaining nut on the top of the regulator, remove the air supply to the positioner, remove the barbed tee, and reconnect the flexible tubing from the regulator to the barbed fitting on the side of the driver module.
9. Install the plastic board cover. Insert the three retaining screws through the plastic cover into the threaded boss and tighten evenly, using a Phillips screwdriver. Do not overtighten (see Figure 15).
10. Reinstall all covers.

8.4 Spool Valve

The spool valve routes the supply air to one side of the actuator while venting the opposite side (see Figure 1). The position of the spool valve is controlled by the driver module.

Replacing the Spool Valve

To replace the spool valve, refer to Figures 12, 14 and 25 and proceed as outlined below. The following tools are required:

- Phillips screwdriver

1. Make sure the valve is bypassed or in a safe condition.
2. Disconnect the power and air supply to the unit.
3. Remove the spool valve cover by removing the screw and sliding the cover assembly backwards until the tab is clear of the slot. It is not necessary to remove the sheet metal cap, hydrophobic filter, or O-ring from this assembly (Figure 14).

⚠ **WARNING:** The spool (extending from the driver module assembly) is easily damaged. Use extreme caution when handling spool and spool valve block. Do not handle the spool by the machined portions of spool. The tolerances between the block and spool are extremely tight. Contamination in the block or on the spool may cause the spool to hang.

4. Remove the spool valve block by removing the two Phillips-head screws and carefully sliding the block off the spool (Figure 12).
5. Carefully remove spool by sliding end of spool out of connecting clip. Excessive force may bend the spool.
6. Verify that the three O-rings are in the counterbores on the machined platform where the new spool valve block is to be placed (Figure 25).
7. Carefully slide the spool into the connecting clip of the driver module assembly.
8. Carefully slide the block over the spool, using the machined surface of the housing base as a register (Figure 12). Slide the block toward the driver module until the two retaining holes line up with the threaded holes in the base.
9. Install two spool valve screws and tighten securely with a Phillips screwdriver (see Figure 13).
10. Slide the spool valve cover assembly over the spool valve until the tang engages into the housing slot. Install the spool valve cover screw and tighten securely (see Figure 12).
11. Reconnect power and air supply to the positioner and perform a stroke calibration.

8.5 Spool Valve Cover

The spool valve cover incorporates a coalescing filter element in a two-piece cover. This protects the spool valve chamber from dirt and moisture and provides a low back pressure vent for exhaust air from the spool valve.

Replacing Filter in Spool Valve Cover

To replace the filter in the spool valve cover, refer to Figures 12 and 17 and proceed as outlined below. The following tools are required:

- Phillips screwdriver

1. Remove the spool cover by removing the screw and sliding the cover assembly backwards until the tab is clear of the slot. The sheet metal cover may be removed and cleaned with a brush or by blowing out with compressed air (Figure 12).
2. Remove the O-ring from around the hydrophobic filter element and set aside (Figure 17).
3. Remove the molded filter element by pulling it straight out of the chamber cover vent piece.
4. Install O-ring into base of chamber cover vent piece as shown in Figure 17.
5. Place new molded filter element into the chamber cover vent piece. This filter element provides part of the track to secure the O-ring installed in the last step.
6. Place spool valve shroud onto spool valve cover.
7. Place the spool valve cover assembly in place by setting it on the ramp and sliding it until the tab seats in the slot (Figures 12 and 17) and secure with a 8-32 screw.

Figure 17: Spool Valve Cover Assembly

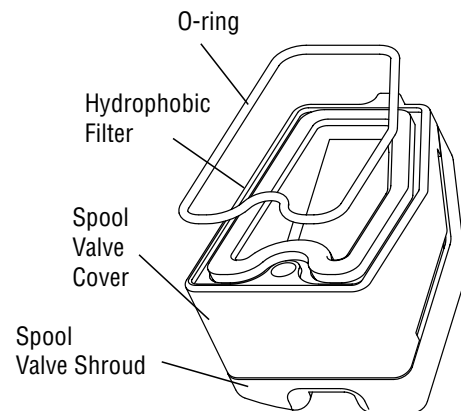
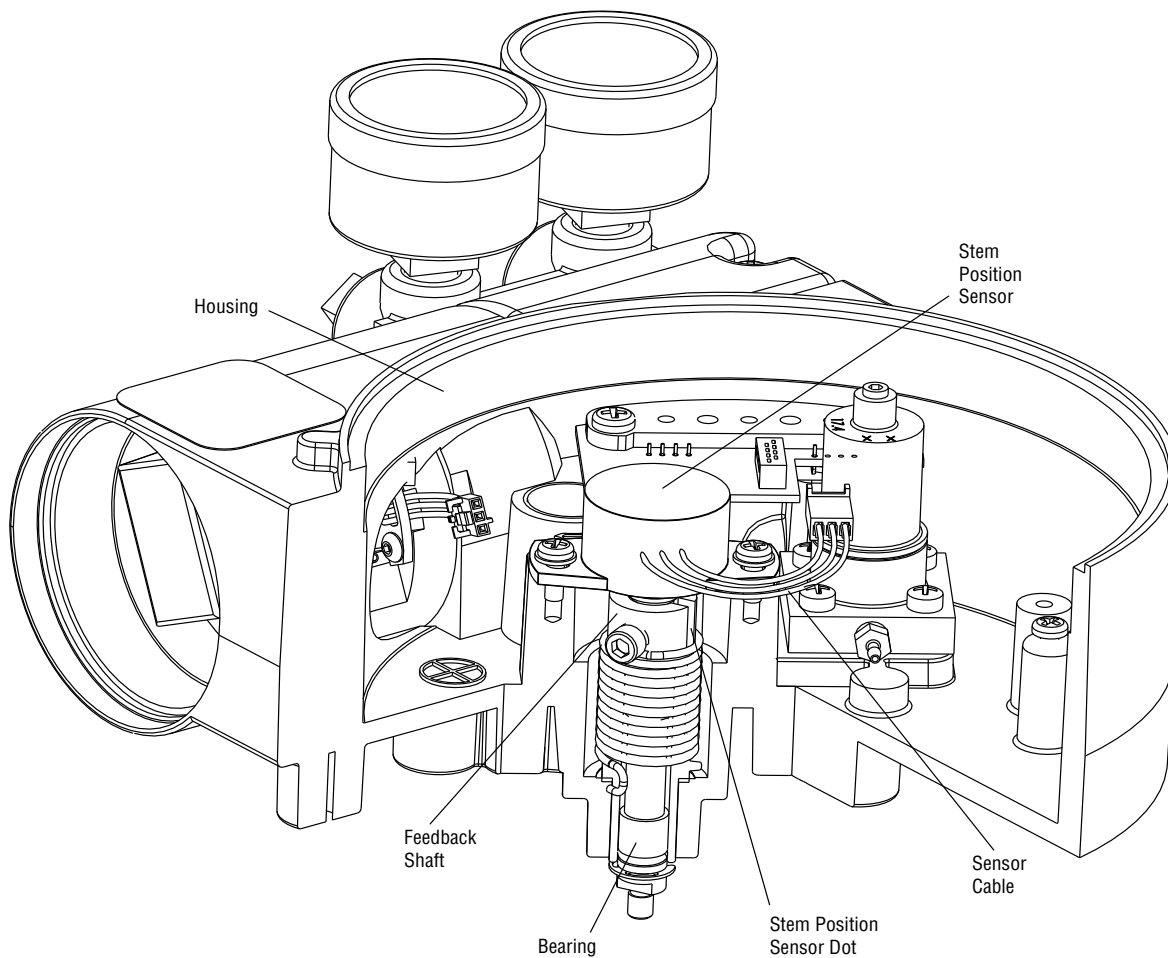

Figure 18: Stem Position Sensor Orientation



8.6 Stem Position Sensor

The position feedback assembly transmits valve positions information to the processor. This is accomplished by means of a rotary position sensor that connects to the valve stem through a feedback linkage. To provide for accurate tracking of the pin in the slot, the follower arm is biased against one side of the slot with a rotary spring. This spring also automatically moves the position feedback assembly to its limit in the unlikely event of failure of any component in the linkage.

Stem Position Sensor Replacement

To replace the stem position sensor, refer to Figure 15, 18 and 25 and proceed as outlined below. The following tools are required:

- Phillips screwdriver

⚠ **WARNING:** Observe precautions for handling electrostatically sensitive devices.

1. Make sure the valve is bypassed or in a safe condition.
2. Disconnect the power and air supply to the unit.
3. Remove the main cover.
4. Remove the plastic board cover by removing the three retaining screws (see Figure 15).
5. Disconnect the position sensor wires from the main PCB assembly.
6. Remove the two rotary position sensor-retaining screws and lift the sensor out of the housing.
7. Turn the new position sensor shaft until the dot on the side of the shaft is aligned with the wires on the side of the position sensor (Figure 18).
8. Insert the position sensor into the shaft with the wires pointing toward the main PCB assembly. Turn the position sensor clock-

wise until bolting slots align with the housing screw holes and the wires on the sensor protrude over the main PCB assembly.

Note: Do not mix the position sensor with those from older Logix positioners. Older models contain sensors with different ranges that will not work in the Logix 3200MD model. The wires on the Logix 3200MD position sensor are red, white and black.

9. Carefully center the position sensor on the shaft bore, insert and tighten the screws. Do not overtighten.
10. Route the wires along the side of the position sensor and reconnect to the main PCB assembly.
11. Install the plastic board cover. Insert the three retaining screws through the plastic cover into the threaded boss and tighten evenly, using a Phillips screwdriver. Do not overtighten (see Figure 15).
12. Reinstall all covers.
13. Reconnect power and air supply to the positioner and perform a stroke calibration.

8.7 Main PCB Assembly

The main printed circuit board (PCB) assembly contains the circuit board and processor that perform control functions of the positioner. The main PCB is to be replaced as a unit. None of the components on the main PCB are serviceable.

Replacing Main PCB Assembly

To replace the main PCB assembly, refer to Figure 11 and 15 and proceed as outlined below. The following tools are required:

- Phillips screwdriver

⚠ **WARNING:** Observe precautions for handling electrostatically sensitive devices.

1. Make sure the valve is bypassed or in a safe condition.
2. Disconnect the power and air supply to the unit.
3. Remove the main cover.
4. Remove the plastic board cover by removing the three retaining screws (see Figure 15).
5. Remove the five wire connections from the main PCB assembly (six wire connections if the unit is equipped with the 4-20 mA analog output option) (see Figure 11).
6. Remove the retaining screw from the main PCB assembly and lift the main PCB out of the housing (see Figure 15).

7. Install the new main PCB into the housing. Insert the retaining screw through the board into the threaded boss and tighten, using a Phillips screwdriver. Do not overtighten.
8. If the old main PCB is equipped with a 4-20 mA analog output board, gently lift the board off the main PCB. Align the two connectors of the 4-20 mA output board with the mating sockets on the main PCB and gently press the connectors together.
9. Reinstall the five wire connections (six wire connections if the unit is equipped with the 4-20 mA analog output option) (see Figure 11).
10. Install the plastic board cover. Insert the three retaining screws through the plastic cover into the threaded boss and tighten evenly, using a Phillips screwdriver. Do not overtighten (see Figure 15).
11. Reinstall all covers.
12. Reconnect power and air supply to the positioner and reconfigure the positioner being sure to perform a stroke calibration.

8.8 Pressure Sensor Board

The pressure sensor board contains two pressure sensors that measure the pressure on output ports 1 and 2. The actuator pressure sensors are used in the positioner control algorithm to enhance valve stability. In positioners with Advanced diagnostics, pressure data is gathered for supply pressure alarm, signatures and data logging. In positioners with Pro diagnostics, pressure data is used for full on-line diagnostic analyses. For optimal performance, the actuator pressure sensors need to be calibrated. The actuator pressure sensor calibration is performed using a HART 375 Handheld Communicator or configuration software such as ValveSight.

Removing the Pressure Sensor Board

To replace the pressure sensor board, refer to Figures 11, 15 and 25 and proceed as outlined below. The following tools are required:

- Phillips screwdriver

⚠ **WARNING:** Observe precautions for handling electrostatically sensitive devices.

1. Make sure the valve is bypassed or in a safe condition.
2. Disconnect the power and air supply to the unit.
3. Remove the main cover.
4. Remove the plastic board cover by removing the three retaining screws (see Figure 15).
5. Disconnect the ribbon cable on the pressure sensor board from the PCB assembly (see Figure 11).

6. Remove the two screws holding the pressure sensor board to the housing. Lift the metal stiffener plate off the pressure sensor board and set aside for future use.
7. Remove the pressure sensor board.

Installing the Pressure Sensor Board

The pressure sensor board is installed on the advanced model only. To install the pressure sensor board, refer to Figures 11, 15 and 25 and proceed as outlined below. The following tools are required:

- Phillips screwdriver
- Torque wrench

⚠ WARNING: Observe precautions for handling electrostatic sensitive devices.

1. Verify that the two pressure sensor O-rings (item 15) are in place in the housing.
2. Set the pressure sensor board assembly in place so that the O-rings make contact with the faces of the pressure sensors.
3. Place the metal stiffener plate (item 12) on top of the pressure sensor board over the pressure sensors and align the two holes in the pressure sensor plate with the threaded bosses in the housing.
4. Insert two screws through the stiffener plate and pressure sensor board into the threaded holes in the housing and tighten evenly, to 8 in-lb.
5. Connect the ribbon cable on the pressure sensor board to the main PCB assembly.
6. Install the plastic board cover. Insert the three retaining screws through the plastic cover into the threaded boss and tighten evenly, using a Phillips screwdriver. Do not overtighten.
7. Reinstall all covers.
8. Reconnect power and air supply to the positioner. Use ValveSight or a handheld communicator to perform a pressure sensor calibration.

8.9 Customer Interface Board

The customer interface board provides a connection point inside the explosion-proof housing for all hookups to the positioner. Calibration of the loop current and the analog output current (optional) are performed using a HART 375 Handheld Communicator or configuration software such as ValveSight.

Replacing the Customer Interface Board

To replace the customer interface board, refer to Figures 6, 11, 15 and 25 and proceed as outlined below. The following tools are required:

- Phillips screwdriver

⚠ WARNING: Observe precautions for handling electrostatic sensitive devices.

1. Make sure the valve is bypassed or in a safe condition.
2. Disconnect the power and air supply to the unit.
3. Remove the main cover.
4. Remove the plastic board cover by removing the three retaining screws (see Figure 15).
5. Remove the five wire connections from the main PCB assembly (six wire connections if the unit is equipped with the 4-20 mA analog output option) (see Figure 11).
6. Remove the retaining screw from the main PCB assembly and lift the main PCB out of the housing (see Figure 15).
7. Remove the user interface cover.
8. Disconnect the field wiring from the customer interface board terminals and remove the three screws that hold the customer interface board in the housing (see Figure 6).
9. Remove the customer interface board, carefully pulling the wiring through the bore.
10. Verify that the O-ring is in place in the counterbore in the positioner housing.
11. Feed the wires on the back of the new customer user interface board through the passageway into the main chamber of the housing.
12. Set the customer interface board in place and secure with three screws (see Figure 6).
13. Reconnect the field wiring to the customer interface board terminals.
14. Install the main PCB into the housing. Insert the retaining screw through the board into the threaded boss and tighten evenly, using a Phillips screwdriver. Do not overtighten.
15. Reinstall the five wire connections (six wire connections if the unit is equipped with the 4-20 mA analog output option) on the main PCB assembly (see Figure 11).

16. Install the plastic board cover. Insert the three retaining screws through the plastic cover into the threaded boss and tighten evenly, using a Phillips screwdriver. Do not overtighten (see Figure 15).

17. Reinstall all covers.

9 Optional Hardware

9.1 Vented Design (See Figures 19 and 20)

A standard Logix 3200MD positioner is vented directly to the atmosphere. When supply air is substituted with sweet natural gas, piping must be used to route the exhausted natural gas to a safe environment. This piping system may cause some positioner back pressure in the main chamber (from the modulator and regulator) and spool chamber (from the actuator). Back pressure limitations are described below.

Two chambers must be vented on the Logix 3200MD positioners: the main housing chamber and the spool valve chamber (Figures 19 and 20). The main chamber vent is located on the backside of the positioner (see Figure 19). Vented-design Logix 3200MD positioners are supplied from the factory with a fitting installed in the main chamber vent. Connect the necessary tubing/piping to this fitting to route the exhausted natural gas to a safe environment.

The maximum allowable back pressure from the collection device on the main housing vent is 2.0 psig (0.14 barg). Vent flow rate is 0.5 std ft³/min (1.4 std liter/min).

⚠ WARNING: The back pressure in the main housing must never rise above 2.0 psig (0.14 barg).

Figure 19: Main Housing Vent

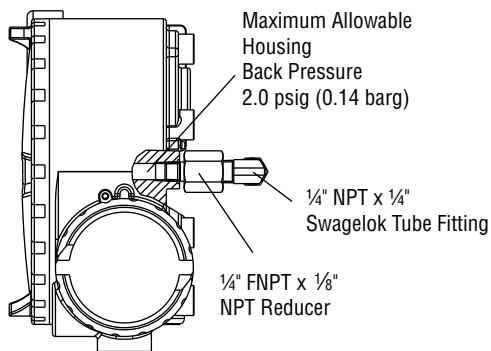
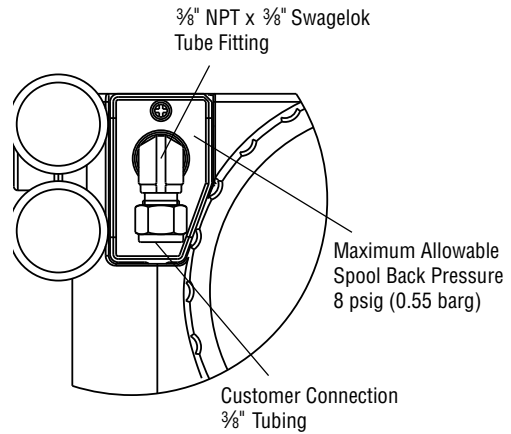

Figure 20: Spool Cover Vent



The spool valve chamber (see Figure 20) must also be vented through the spool valve cover. Vented-design Logix 3200MD positioners are supplied from the factory with a fitting installed in the spool valve cover (item SKU 179477). Connect the necessary tubing/piping to this fitting to route the exhausted natural gas to a safe environment. The maximum allowable back pressure in the spool valve chamber is 8 psig (0.55 barg). Pressures greater than 8 psig will cause vented gas to leak past the spool cover O-ring to the atmosphere and will result in overshoot of the positioner.

9.2 HART Modem

The HART modem is a device that connects to the serial communications port of a computer. This modem converts the RS-232 COM port signals to the HART signal. A HART modem is optional in ValveSight since a MUX can be used in its place. The HART modem takes power from the RS-232 COM port lines. If using a laptop computer running on an internal battery, HART communication may become erratic as the batteries begin to lose charge. This is due to a reduction in HART modem power. Allow batteries to recharge or apply AC adapter power to the laptop to correct the problem. A HART modem is available through your Flowserve representative. (Please refer to Section 11 for part numbers.)

When using a HART modem with ValveSight or when using the HART 375 handheld, the leads can be connected anywhere across the 4-20 mA current signal. The leads are not polarity sensitive. When using a filter, the connection must be made between the filter output and the Logix 3200MD (see Figure 22).

9.3 4-20 mA Analog Output Board

The Logix 3200MD digital positioner can be supplied to provide an analog feedback signal of the stem position. This option can also be retrofitted in the field. The 4-20 mA analog output board is wired in series with a 12.5 to 40 VDC power supply (see Figure 23). This position feedback option has the following features and specifications:

- Does not interfere with positioner operation.
- Calibration of the analog output signal is performed using a HART 375 Handheld Communicator or configuration software such as ValveSight.
- Output follows actual position of valve, including all failure modes of positioner except loss of power. An output of ≤ 3.15 mA is transmitted with loss of power to the positioner.
- Immune to RFI/EMI disturbances.
- Available for explosion-proof and safe applications (CSA, FM).

Replacing the 4-20 mA Analog Output Board

To replace the 4-20 mA analog output board, refer to Figures 11, 15 and 25 and proceed as outlined below. The following tools are required:

- Phillips screwdriver

WARNING: Observe precautions for handling electrostatically sensitive devices.

Figure 23: Analog Output Board Power

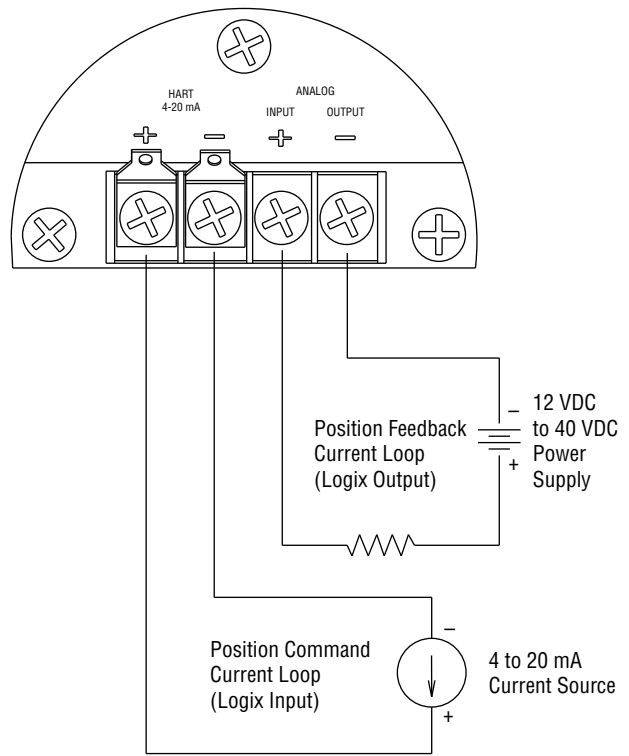

CAUTION: Isolated Power Sources Required.

CAUTION: Isolated power sources required.

1. Make sure the valve is bypassed or in a safe condition.
2. Disconnect the power and air supply to the unit.
3. Remove the main cover.
4. Remove the plastic board cover by removing the three retaining screws (see Figure 15).
5. Disconnect the two wire connection from the side of the 4-20 mA analog output board.
6. Gently lift the 4-20 mA analog output board off the main PCB assembly.

Figure 22: HART VHF Filter Schematic

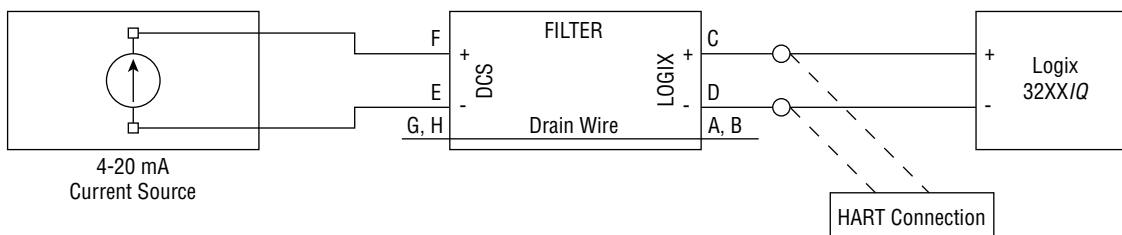

7. Align the two connectors on the new 4-20 mA analog output board with the mating sockets on the main PCB board and gently press the connectors together.
8. Connect the two wire connection coming from the User Interface board to the side of the 4-20 mA analog output board.
9. Install the plastic board cover. Insert the three retaining screws through the plastic cover into the threaded boss and tighten evenly, using a Phillips screwdriver. Do not overtighten.
10. Connect the Analog Output filed termination wiring to the Analog Output terminals on the User Interface board (see Figure 23.)
11. Reinstall all covers.

Figure 24: 4-20 mA Analog Output Board

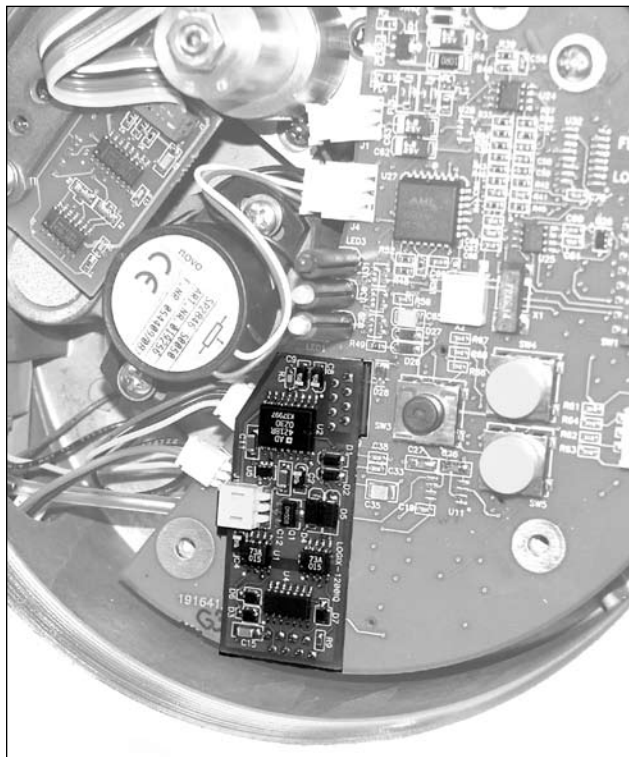

10 Parts List

Item No.	Part	Item No.	Part
1	Housing Logix 3000MD Positioner	29	Main Vent Cover
2	Main Housing Cover	30	Screw, Main Vent Cover
3	O-ring, Main Housing Cover	31	Driver Module Cover
4	Screw, Anti-rotation	32	O-ring, Driver Module Cover
5	Plastic Main PCB Cover	33	Driver Module Assembly
6	Screw, Main PCB Cover Short (2)	34	Hex Barbed Fitting with Captive O-ring
7	Screw, Main PCB Cover Long	35	Flexible Tubing
8	Main PCB Assembly	36	Screw, Driver to Housing
9	Screw, Main PCB Assembly Retaining	37	Nylon Washer
10	4-20 mA Analog Output Board (Optional)	38	Spool Valve
11	Screw, Pressure Sensor Board (2)	39	Spool Valve Block
12	Pressure Sensor Board Stiffener	40	Screw, Spool Valve to Housing (2)
13	Pressure Sensor Board (Advanced Only)	41	O-ring, Spool Valve (3)
14	Pressure Sensor Plug Plate (Standard Only)	42	Screw, Spool Valve Cover
15	O-ring, Pressure Sensor to Housing (2)	43	Spool Valve Shroud
16	Pressure Regulator, 5 to 30 psig (Includes 2 O-rings)	44	Spool Valve Cover
17	Screw, Regulator Plate to Housing (4)	45	Hydrophobic Filter, Spool Valve Chamber
18	Hex Barbed Fitting with Captive O-ring	46	O-ring, Spool Valve Cover
19	Internal Filter	47	Pressure Gauge, 0-160 psig (2)
20	O-ring, Interface Plate to Housing Seal	48	Air Screen (3)
21	Customer Interface Cover	49	Screw, Position Feedback Potentiometer to Housing (2)
22	O-ring, Customer Interface Cover	50	Metal Washer (2)
23	Screw, Anti-rotation	51	Position Feedback Potentiometer
24	Screw, Customer Interface Board (3)	52	Feedback Shaft
25	Customer Interface Board	53	Screw, Spring to Feedback Shaft
26	O-ring, Customer Interface Board	54	O-ring, Feedback Shaft
27	Grounding Screw (2)	55	Torsion Spring
28	Threaded Plug	56	E-ring

Figure 25: Exploded Drawing

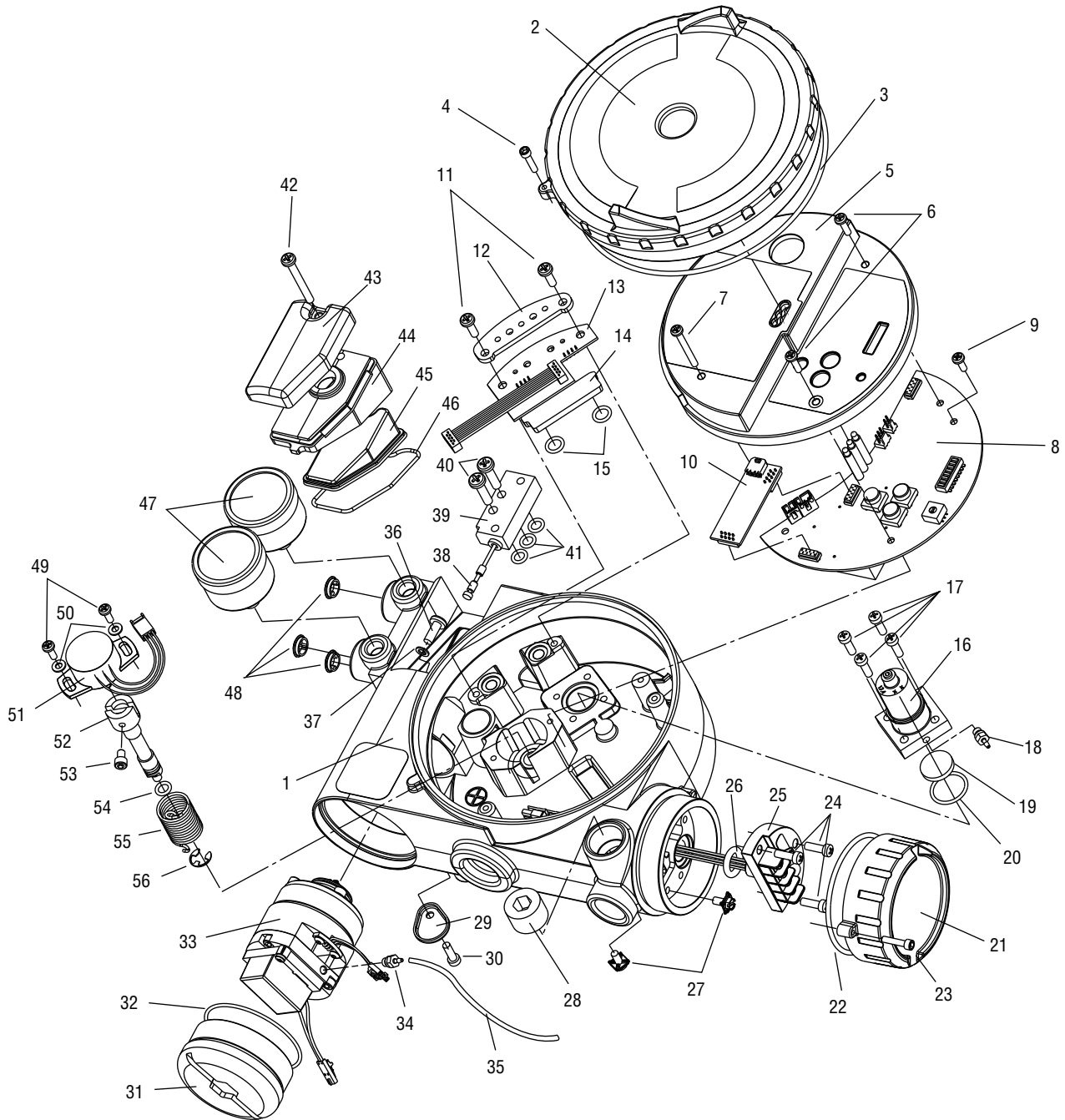

11 Logix 3200MD Spare Parts Kits

See Figure 25 for item numbers.

Item No.	Description	Quantity
Kit 2: Driver Module Assembly -40° to 80°C Kit, P/N 199786.999.000		
16	Pressure Regulator	1
17	Screw, Regulator to Housing	4
33	Driver Module Assembly	1
34	Hex Barbed Fitting w/ Captive O-ring	1
36	Screw, Driver to Housing	1
37	Nylon Washer	1
Kit 3: Spool Assembly Valve Kit, P/N 199787.999.000		
38	Spool	1
39	Spool Valve Block	1
40	Screw, Spool Valve to Housing	2
41	O-ring, Spool Valve	3
Kit 4: Pressure Regulator, P/N 215814.999.000		
16	Pressure Regulator with Captive O-rings	1
17	Screw, Regulator to Housing	4
Kit 5: Feedback Shaft Kit, P/N 199788.999.000		
52	Feedback Shaft	1
53	Screw, Spring to Feedback Shaft	1
54	O-ring, Feedback Shaft	1
55	Torsion Spring	1
56	E-ring	1
Kit 6: Feedback Shaft Kit (NAMUR), P/N 218814.999.000		
52	Feedback Shaft	1
53	Screw, Spring to Feedback Shaft	1
54	O-ring, Feedback Shaft	1
55	Torsion Spring	1
56	E-ring	1

Item No.	Description	Quantity
Kit 7: Soft Goods Kit, P/N 199789.999.000		
3	O-ring, Main Housing Cover	1
15	O-ring, Pressure Sensor to Housing	2
20	O-ring, Regulator to Housing	1
22	O-ring, Customer Interface Cover	1
26	O-ring, Customer Interface Board	1
35	Flexible Tube	1
37	Nylon Washer	1
41	O-ring, Spool Valve to Housing	3
45	Hydrophobic Filter, Spool Valve Chamber	1
46	O-ring, Spool Valve Cover	1
54	O-ring, Feedback Shaft	1
Kit 8: Pressure Sensor Board Kit, P/N 199791.999.000		
11	Screw, Pressure Sensor Board	2
13	Pressure Sensor Board	1
15	O-ring, Pressure Sensor to Housing	2
Kit 9: Main PCB Assembly Kit, P/N 255014.999.000		
6	Screw, Main PCB Cover Short	2
7	Screw, Main PCB Cover Long	1
8	Main PCB	1
9	Screw, Main PCB Retaining Screw	1
Kit 10: User Interface Board Kit, P/N 199793.999.000		
24	Screw, Customer Interface to Housing	3
25	Customer Interface Board	1
26	O-ring, Customer Interface Board	1
Kit 11: Analog Output Board Kit, P/N 218795.999.000		
10	Analog Output Board	1
Kit 12: Position Feedback Potentiometer Kit, P/N 199794.999.000		
49	Screw, Feedback Potentiometer to Housing	2
50	Metal Washer	2
51	Position Feedback Potentiometer	1
HART Modem		
RS 232	P/N 138203.999.000	
PCMICIA	P/N 138204.999.000	
USB	P/N 216421.999.000	

12 Logix 3200MD Mounting Kits

12.1 Valtek Mounting Kits

Table IX: Valtek Linear Mounting Kits

Spud	25 in ²		50 in ² *		100-200 in ²	
	Standard	Handwheel	Standard	Handwheel	Standard	Handwheel
2.00	164432	164433	164434	164433		
2.62			164435	164436	164437**	164436
2.88					164437	164438
3.38					164439	164440
4.75					164439	164440

* A 50 square", 2.00 spud with live loading requires kit number.

** Live-loading is not available on a 100 in², 2.62 spud.

Table X: Valtork Rotary Mounting Kits*

Spud	25 in ²		50 in ² *		100-200 in ²	
	Standard	Optional	Standard	Optional	Standard	Optional
0.44	135429	135432	135430		135431	
0.63	135429	135437	135430	135433	135431	
0.75	135429	135438	135430	137212	135431	
0.88	135429	135439	135430	137213	135431	135434
1.12	135429		135430	137214	135431	137215
1.50	135429		135430		135431	137216
1.75	135429		135430		135431	137217

* Standard: All rotary valves with standard accessories (end of shaft mount).

Optional: All rotary valves with handwheels or volume tanks (linkage design).

12.2 Logix O.E.M. Mounting Kits

Table XI: Logix O.E.M. Mounting Kits

Brand	Model	Size	Mounting Kit	
Fisher	657 & 667	30	213905	0.5" – 1.5" stroke
		34	141410	
		40		
		50	171516	0.5" – 1.5" stroke
			171517	2" stroke
		60	171516	0.5" – 1.5" stroke
			171517	2" stroke
		70	171518	4" stroke
	80	171519		
	1250	225	173371	
		450		
		675		
1052	33	171549	Rotary	
657-8	40	173798		
Netes	RC		171512	
	RD		178258	
Foxboro	Slid-Std		173567	
	Linear		178258	
Honeywell	VST-VA3R	17-in. dia.	173798	
	VSL-VA1D	12-in. dia.	173798	
Masoneilan (Linear Actuators)	37	9	171721	
		11		
		13		
		18		
		24		
	38	11	173235	
		13	173234	
		15	186070	
		18	173382*	
		24	173896	
	71 Domotor	25	173325	
		50	173335	
		100	173336	
	88	6	171722	
		16	173827	
	47	B	173361	
	48	B	173361	
	"D" Domotor	200	175141	
	71-2057AB-D		176179	
	71-40413BD		176251	

Table XI: Logix O.E.M. Mounting Kits (continued)

Brand	Model	Size	Mounting Kit	
Masoneilan (Rotary Actuators)	33	B	173298	
	35	4	173298	
		6		
		7		
70	10	173298		
Valtek	Trooper		166636	0.75" – 1.50" Std
Automax	R314		141180	HD
	SNA115		NK313A	
Vanguard	37/64	175128		
Air-Torque	AT Series	AT0 – AT6		
Automax	SNA Series	SNA3 – SNA2000		
	N Series	N250.300		
	R Series	R2 – R5		
Bettis	RPC Series	RP – TPC11000		
	G Series	G2009-M11 – G3020-M11		
EL-O-Matic	E Series	E25 – E350		
	P Series	P35 – P4000		
Hytork	XL Series	XL45 – XL4580		
Unitorq	M Series	M20 – M2958		
Worcester	39 Series	2539 - 4239		

*Adjustable mounting kit 173798 may be needed if handwheels are used.

12.3 NAMUR Accessory Mounting Kit Part Numbers

Use prefix "NK" and choose bracket and bolt options from the following table.

Table XII: NAMUR Accessory Mounting Kit Part Numbers

Bracket Option	Description
28	20 mm pinion x 80 mm bolt spacing
28	38 mm pinion x 80 mm bolt spacing
313	30 mm pinion x 80 mm bolt spacing
513	50 mm pinion x 130 mm bolt spacing
Bolt Option	Description
A	10-24 UNC bolting
B	10-32 UNF bolting
L	M5-.8 metric bolting

Example: NK313A, NAMUR Accessory Mounting Kit with 30 mm pinion x 80 mm bolt spacing and 10-24 UNC bolting.

13 Frequently Asked Questions

Q: My DCS uses 24 VDC, can I run a Logix 3200MD?

A: A DCS output current card does run from 24 VDC but the card regulates the actual current output. However, if the 24 VDC were applied directly across the terminals, nothing would limit the current and the Logix 3200MD Field Termination Board could be damaged. The current source voltage supply can be anywhere between 10 VDC to 30 VDC as long as the current is limited in the 4-20 mA range.

Q: I accidentally placed a voltage supply across the Logix 3200MD. How do I know if I damaged something?

A: The typical failure in an over-current situation is a short circuit. Your loop current will be maintained but the Logix 3200MD control board will receive no power. With power removed from the Logix 3200MD, use an ohmmeter to measure across the terminals. If the reading is a short (close to zero ohms), the Customer Interface Board must be replaced. Make sure the positive lead is on the '+' terminal and negative lead is on the '-' terminal when measuring the resistance.

Q: What is the input resistance of the Logix 3200MD?

A: The Logix 3200MD does not have a simple resistive input. When measuring the voltage across the Logix 3200MD, it only varies slightly when the current is changed from 4 mA to 20 mA (9.8 to 10.0 VDC nominal without HART communications. Add 0.3 V with HART active). This is because the Logix 3200MD is an active device. The resistance at a given current is commonly referred to as the effective resistance.

$\text{Effective Resistance} = (\text{Terminal Voltage}) / \text{Current}$	Equation 3
--	------------

For example:

at 20 mA: Effective resistance = 9.9 VDC/0.02 A = 495 Ω

The Logix 3200MD has a specification of 495 Ω @ 20 mA.

NOTE: You cannot measure across the terminals of an unpowered Logix 3200 and get the effective resistance.

Q: How do I know if I need a VHF HART filter?

A: If the current source is interfering with communication, it will affect both ValveSight and the HART 375 handheld. If the positioner communicates to ValveSight or the HART 375 handheld when using a current source (a 4-20 mA current calibrator, for example) and not the DCS, it indicates a filter is necessary with that current source. Some 4-20 mA calibrators that work without a filter are listed below. If one of these is available, try to connect with ValveSight or the HART 375 handheld again. If communications are established while using one of these sources but fails on the original source, a filter is needed.

Handheld 4-20 mA calibrators which do not require a filter:

- Altek Model 334
- Rochester Instrument Systems (RIS) CL-4002
- Unomat UPS-II

Q: I set the MPC at 5 percent. How will the positioner operate?

A: Assume that the present command signal is at 50 percent. If the command signal is decreased, the positioner will follow the command until it reaches 5 percent. At 5 percent, the spool will be driven fully open or fully closed, depending on the air action of the valve, in order to provide full actuator saturation and tight shutoff. The positioner will maintain full saturation below 5 percent command signal. As the command increases, the positioner will remain saturated until the command reaches 6 percent (there is a 1 percent hysteresis value added by the positioner). At this point, the stem position will follow the command signal. While in MPC, the Logix 3200MD LEDs will blink GGGY.

Q: I have MPC set to 3 percent but the valve will not go below 10 percent.

A: Is a lower soft stop enabled? The lower soft stop must be less than the lower PMC setpoint in order for the lower MPC to become active. When the lower soft stop is reached, the positioner will blink a GYGY code. When MPC is active, the positioner will blink GGGY.

Q: Will soft stops prevent the valve from going to its fail position?

A: No.

Q: What is the difference between models with Standard (3200MD), Advanced (3210MD) and Pro (3220MD) diagnostics?

A: All models use the pressure sensors in the positioner control algorithm to enhance valve stability. The model with Advanced diagnostics performs calculations such as detection of loss of pressure, diagnostic signatures and data logging. The model with Pro diagnostics adds full diagnostic capabilities including continuous on-line friction, pneumatic leak and actuation ratio analysis. Pro diagnostics support comprehensive health views in the ValveSight DTM. Partial stroke tests and long term trends of many key parameters are also available with Pro diagnostics.

Q: Can I upgrade from a Standard to Advanced or from Advanced to Pro diagnostics?

A: Yes. Upgrading can be accomplished using ValveSight DTM software. After upgrading, pressure and friction calibrations can be performed using the ValveSight DTM or the HART 375 handheld.

Q: Can I add pressure sensors to my 3200IQ and upgrade it to a 3220MD with Pro diagnostics?

A: This depends on the certifying agency. Some agencies do not allow field upgrades which change the physical configuration. If the certifying agency allows physical upgrades, the pressure sensor board assembly can be purchased and installed. A Flowserve technician can update the positioner software from IQ to the desired MD version (Advanced or Pro). If the certifying agency does not allow physical upgrades, a Flowserve technician can update the positioner software from the IQ to the desired MD version (Advanced or Pro). If the certifying agency does not allow physical upgrades, a Flowserve technician can update the positioner software to turn the 3200IQ into a 3200MD (with Standard diagnostics) allowing it to work with the ValveSight DTM. See the Logix 3200IQ IOM for instruction on removing the plug plate and installing the pressure sensors.

14 How to Order

Selection		Code	Example
		3	3
Protocol	HART	2	2
Diagnostics	Standard	0	1
	Advanced (with pressure sensing)	1	
	Pro (with sensing and full ValveSight diagnostics)	2	
Material	Aluminum, White Paint (Valtek)	0	0
	Stainless Steel, No Paint (Valtek)	1	
	Aluminum, Black Paint (Automax)	2	
	Aluminum, Food-Grade White Paint (Automax)	3	
	Aluminum, Black Paint (Accord)	4	
	Aluminum, Food-Grade White Paint (Accord)	5	
Design Version			MD
Certifications	Nonincendive Ex nL nA IIC, ATEX II 3 G, T4 Tamb -40°C to +85°C, T5 Tamb -40°C to +55°C; Intrinsically Safe Ex ia IIC, T4 Tamb -40°C to +85°C, T5 Tamb -40°C to +55°C; Ex ia D 20, T95°C -40°C to +80°C (CENELEC)	04	14
	INMETRO BR-EX ia IIC T4/T5; BR-Ex d IIB+H ₂ , T5 (South America)	06	
	Explosionproof EEx d IIB + H ₂ , ATEX II 2 G (CENELEC)	07	
	Explosionproof Class I, Div 1, Groups B, C, D Intrinsically Safe Class I, Div 1, Groups A through G (FM, CSA) FM Nonincendive. CSA Class I, Div 2, Class I, Zone 1, Group IIB + H ₂ and Exia Class 1, Zone 0, Group IIC (CSA Only)	10	
	General Purpose	14	
	Intrinsically Safe Ex ia IIC, T4 Tamb -40°C to +85°C, T5 Tamb -40°C to +55°C; Ex ia D 20, T95°C -40°C to +80°C, ATEX II 1 G D (CENELEC) (GOST)	15	
	IECEX Explosionproof	16	
	IECEX Intrinsically Safe	21	
Shaft	DD 316 Stainless Steel Shaft (Valtek Standard)	D6	D6
	NAMUR 316 Stainless Steel (VDI/VDE 3845)	N6	
Conduit Connections	½" NPT	E	M
	M20	M	
Action	Four-way (Double-Acting)	04	4V
	Three-way (Single-Acting)	03	
	Four-way Vented (Double-Acting)	4V	
	Three-way Vented (Single-Acting)	3V	
Temperature	Low Temperature (-40°F to 176°F; -40°C to 80°C)	40	40
Gauges	SS with brass internals, psi (bar/kPa) (Valtek Standard)	OG	KS
	SS with SS internals, psi (bar/kPa)	OS	
	SS with brass internals, psi (kg/cm ²)	KG	
	SS with SS internals, psi (kg/cm ²) KS	KS	
	No Gauges	U	
Special Options	No special options	00	OF
	4-20 mA Position Feedback	OF	
	Remote Mount Feedback (Only Available with Certification Option 14)	RM	
	Fail Option Feedback*	SF	

For each category, select the code for one of the options.

*Contact factory before specifying this option

15 Troubleshooting

Failure	Probable Cause	Corrective Action
No LED is blinking	Current source below 3.6 mA without AO card or 3.7 mA with AO card	Verify current source is outputting at least 3.6 mA with AO card or 3.7 mA with AO card
	Incorrect wiring polarity	Check wiring for correct polarity
	Voltage of current source is not high enough	Verify that current source can supply at least 10 V
Erratic communications	Current source bandwidth not limited to 25 Hz	Maximum allowable current source rate of change is 924 mA per second
	Maximum cable length or cable impedance exceeded	Check cable conduction size, length and capacitance. Refer to Section 6.4, "Cable Requirements"
	HART modem connected to PC RS-232 port not receiving enough power	Verify laptop battery is not low
	Interference with I.S. barrier	Must use HART-compatible I.S. barrier
	Current Source stripping (filtering) HART signal.	Use the HART filter (VHF) available from Flowserve
Unit does not respond to analog commands	Unit is in digital command mode	Switch to analog command mode by doing a Command Source Reset from the local interface or with a handheld communicator or ValveSight (please refer to Section 7.9, "Command Source Reset," or the quick start guide for detailed instructions).
	Error occurred during calibration	Check blink codes on positioner and correct calibration error. Recalibrate
Valve position reading is not what is expected	Positioner tubing backwards	Re-tube the actuator
	Stem position sensor mounting is off 180°	Remount position sensor
	Stroke not calibrated	Perform QUICK-CAL
	Tight shutoff (M.P.C)* is active	Verify settings using PC or handheld software
	Customer characterization or soft stops active	Verify customer characterization and soft stops
Position is driven fully open or closed and will not respond to command	Stroke not calibrated	Check DIP switch settings and calibrate valve stroke
	Inner-loop hall sensor not connected	Verify hardware connections
	Wrong air action entered in software	Check ATO (Air-to-open) and ATC (Air-to-close) settings. Recalibrate
	Actuator tubing backward	Verify ATO/ATC actuator tubing
	Electro-pneumatic converter malfunctioning	Replace electro-pneumatic converter
	Control parameter inner-loop offset is too high/low	Adjust inner-loop offset and see if proper control resumes
Sticking or hunting operation of the positioner	Contamination of the driver module	Check air supply for proper filtering and meeting ISA specifications ISA-7.0.01. Check the spool valve for contamination
	Control tuning parameters not correct	Adjust gain settings using local gain switch
	Packing friction high	Enable the stability DIP switch on the local interface and recalibrate. If problem persists, enable pressure control with handheld communicator or ValveSight and recalibrate
	Corroded or dirty spool valve	Disassemble and clean spool valve

*M.P.C.: Minimum position cutoff